



Q95M-200

GAS-FIRED DIRECT VENT
MODULATING HOT WATER BOILER

INSTALLATION, OPERATION & MAINTANANCE MANUAL



An ISO 9001-2000 Certified Company

DUNKIRK BOILERS
85 Middle Rd.
Dunkirk, NY 14048
www.dunkirk.com



P/N 240006103D, Rev.C [04/2009]

GAS-FIRED DIRECT VENT MODULATING HOT WATER BOILER

Installation Manual Printed in USA • Made In USA

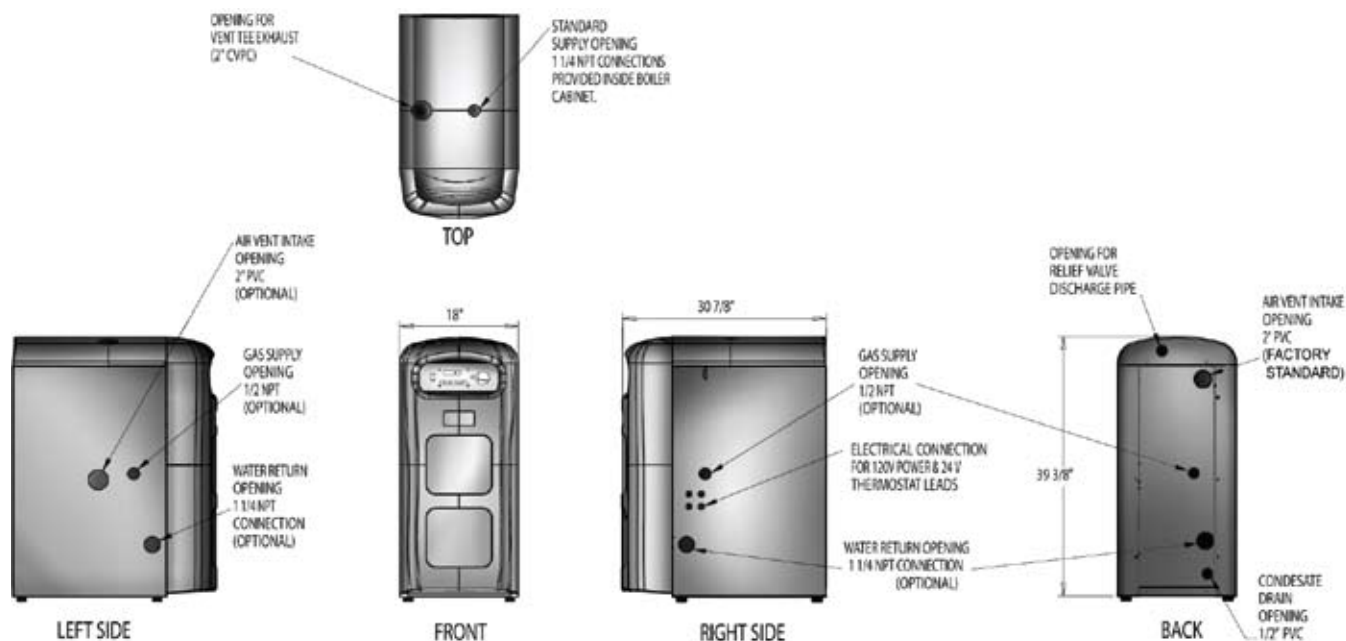

Table of Contents

I - Introduction	2
III - Rules For Safe Installation and Operation	3
IV - Boiler Ratings and Capacities	4
V - Before Installing The Boiler	4
VI - Placing the Boiler	10
VII - Near Boiler Piping	10
VIII - Combustion Air And Vent Pipe.....	12
IX - Gas Supply Piping.....	14
X - Electrical Wiring.....	15
XI - Controls and Accessories	17
XII - Water Treatment & Freeze Protection	19
XIII - Putting the Boiler in Operation.....	22
XIV- Maintenance And Cleaning	23
XV - Boiler Wiring Diagram	27
XVI - Piping and Wiring Appendix	28

I - INTRODUCTION

This appliance is a gas-fired direct vent modulating cast aluminum hot water boiler. A revolutionary cast aluminum monoblock heat exchanger means better heat transfer and thermal storage than similarly sized cast iron boilers, which results in higher efficiency. The heating system water absorbs large amounts of heat from the cast aluminum heat exchanger, cooling the flue gases and causing condensation. Sealed combustion, premix gas burner, and low flame temperature means drastically reduced CO and NOx emissions, which contribute to a cleaner and healthier environment.

This appliance, unlike normal residential atmospheric and induced draft units, takes its combustion air directly from the outdoors (sealed combustion) and does not compete with building occupants for fresh air. Sealed combustion (also known as "direct vent") is the safest and best way to obtain plenty of clean combustion air. The forced draft fan draws in the outside combustion air to mix with gas, which flows into the pre-mix burner and burns. The fan then forces the resulting flue gases from the boiler unit and provides a positive removal of the flue gases from the building through inexpensive and readily available PVC and CPVC pipes. ULC S636 Material must be used in Canada.

NOTICE

IMPORTANT: This boiler is to be installed by a qualified installer only.



NOTICE

Keep this manual near boiler and retain for future reference.



II - SAFETY SYMBOLS AND WARNINGS

The following defined symbols are used throughout this manual to notify the reader of potential hazards of varying risk levels.

	DANGER Indicates an imminently hazardous situation which, if not avoided, will result in death, serious injury or substantial property damage.		CAUTION Indicates an imminently hazardous situation which, if not avoided, may result in injury or property damage.
	WARNING Indicates an imminently hazardous situation which, if not avoided, may result in death, serious injury or substantial property damage.		NOTICE Indicates information which should be followed to ensure proper installation and operation.

III - RULES FOR SAFE INSTALLATION AND OPERATION

	WARNING This appliance has been equipped for residential installations. If used for commercial applications, any and all additional code requirements must be adhered to for installation. This may require additional controls, including but not limited to an external water cut off, a manual reset high temperature limit, and wiring and/or piping modifications. The manufacturer is not responsible for any field installation changes made to a boiler installation which are not described or acknowledged in this manual.	<ol style="list-style-type: none">6. Be sure there is adequate outdoor air supply to boiler for complete combustion.7. Follow a regular service and maintenance schedule for efficient and safe operation.8. Keep boiler area clean of debris and free of combustible and flammable materials.9. Proper through-the-wall or through-the-roof combustion venting shall be in accordance with the materials and methods described in this manual. Installation must comply with local codes.
	NOTICE IMPORTANT: Failure to follow these instructions could cause a malfunction of the boiler and result in death, serious bodily injury, and/or property damage. For assistance or additional information, consult a qualified installer, service agency, or the gas supplier.	<ol style="list-style-type: none">10. This boiler and related hot water heating systems are not do-it-yourself items. They must be installed and serviced by qualified professionals. Ratings above are for sea level applications. The boiler automatically derates input at a rate of 2% for every 1000 feet above an elevation of 2000 feet (see Table 2). The boiler will also derate relative to the calorific value of the gas being used. Use the formula specified in "Measure The Natural Gas Input Rate" in the Control Manual and Troubleshooting Guide (P/N# 240006104) to determine the proper rate due to derated gas. To ensure proper operation at 5,000 feet of altitude and above, the minimum RPM setting; parameter 17, must be raised to 3,200. Instructions on how to change the parameters are included in the Parameter Guide, part number 240006105.
<ol style="list-style-type: none">1. Check all applicable state and local building codes and utility company requirements before installation. This installation must conform with these requirements in their entirety. In the absence of these codes, use NFPA installation codes and good industry practice.2. Before servicing the boiler, allow it to cool. Always shut off any electricity and gas supply connected to the boiler prior to servicing.3. Inspect gas line for leaks.4. Be certain gas input rate is correct. Over firing may result in early failure of the boiler components. This may cause dangerous operation. Under firing may result in too much air for the pre-mix burner causing poor or loss of combustion.5. Never vent the products of combustion from this boiler to an enclosed space. Always vent to the outdoors. Never vent to another room or to inside a building.		

IV - BOILER RATINGS AND CAPACITIES

TABLE 1: SEA LEVEL RATINGS - NATURAL AND PROPANE GASES

Boiler Input Rate (MBH) ⁽¹⁾		Heating Capacity (MBH) ⁽¹⁾⁽²⁾	Net I=B=R Rating (MBH) ⁽¹⁾	AFUE ⁽²⁾	Flue Diameter	Shipping Wt.
High Fire	200	190	165	95%	2" CPVC & 3" PVC	284 lbs.
Low Fire	80	76	66			

⁽¹⁾ 1 MBH = 1,000 BTUH (British Thermal Units Per Hour)

⁽²⁾ Heating Capacity and AFUE (Annual Fuel Utilization Efficiency) are based on DOE (Department of Energy) test procedures.

TABLE 2: 95M-200 HIGH ALTITUDE DERATE CHART

Boiler Input Rate (MBH)	Altitude (In Feet)							
	3,000 (2)	4,000 (2)	5,000 (3)	6,000	7,000	8,000	9,000	10,000
High Fire	196	192	177	174.5	172	169	168	167
Low Fire	78.4	76.8	115	113.5	112	110	109	108

1) Boiler Input Rate is determined at minimum vent length. The rate will decrease as vent length increases.

2) Parameter 17 is set to 2,250 at elevations of 2,000 feet and below.

3) Parameter 17 must be raised to 3,200 at altitudes or elevations of 2,000 feet and above.

These low pressure gas-fired hot water boilers are design certified by CSA International, for use with natural and propane gases. The boilers are constructed and hydrostatically tested for a maximum working pressure of 50 PSIG (pounds per square inch gauge) in accordance with ASME (American Society of Mechanical Engineers) Boiler and Pressure Vessel Code Section IV Standards for heating boilers.

The Boilers are certified in accordance with ANSI (American National Standards Institute) Z21.13 standards as gas-fired, direct vent, condensing, hot water boilers.

The Heating Capacity indicates the amount of heat available after subtracting the losses up the stack. Most of this heat is available to heat water. A small portion is heat loss from the jacket and surfaces of the boiler, and it is assumed that this heat stays in the structure.

The Net I=B=R Rating represents the portion of the remaining heat that can be applied to heat the radiation or terminal units (i.e., finned tube baseboard, cast iron radiators, radiant floor, etc.) The difference between the Heating Capacity and the Net I=B=R Rating, called the piping and pickup allowance, establishes a reserve for heating the volume of water in the system and offsetting heat losses from the piping. The Net I=B=R Ratings shown are based on a piping and pickup factor of 1.15 in accordance with the I=B=R Standard as published by the Hydronics Institute. The Net I=B=R Rating of the boiler selected should be greater than or equal to the calculated peak heating load (heat loss) for the building or area(s) served by the boiler and associated hot water heating systems. The manufacturer should be consulted before selecting a boiler for installations having unusual piping and pickup requirements.

V - BEFORE INSTALLING THE BOILER

Review the following before installing the boiler

This boiler product is a gas-fired, direct vent, condensing boiler and must be installed in accordance with all applicable federal, state and local building codes including, but not limited to the following:

United States - Installation shall conform with National Fuel Gas Code (NFPA-54/ANSI Z223.1 - latest edition)

Canada - Installation shall be in accordance with CSA-B149.1 and .2 installation codes.

Where required by the authority having jurisdiction, the installation must conform to the ASME Safety Code for Controls and Safety Devices for Automatically Fired Boilers, No.CSD-1.

The installation must conform to the requirements of the authority having jurisdiction or, in the absence of such requirements, to the National Fuel Gas Code, ANSI Z223.1 - latest revision.

WARNING



Installers - Follow local regulations with respect to installation of Carbon Monoxide Detectors. Follow maintenance recommendations in this manual.

In the State of Massachusetts, boiler installation must conform to state code 248 CMR which includes but is not limited to:

- This product must be installed by a licensed Plumber or Gas fitter.
- When flexible connectors are used, the maximum length shall not exceed 36 inches.
- When lever type gas shutoffs are used, they shall be T-handle type.

For all side wall horizontally vented gas fueled equipment installed in every dwelling, building or structure used in whole or in part for residential purposes, including those owned or operated by the commonwealth and where the side wall exhaust vent termination is

less than seven (7) feet above finished grade in the area of the venting including but not limited to, decks and porches, the following requirements shall be satisfied:

- 1. Installation of carbon monoxide detectors:** At the time of installation of the side wall horizontal vented gas fueled equipment, the installing plumber or gas fitter shall observe that a hard wired carbon monoxide detector with an alarm and battery back-up is installed on the floor level where the gas equipment is to be installed. In addition, the installing plumber or gas fitter shall observe that a battery operated or hard wired carbon monoxide detector with an alarm is installed on each additional level of the dwelling, building or structure served by the side wall horizontal vented gas fueled equipment. It shall be the responsibility of the property owner to secure the services of qualified licensed professionals for the installation of hard wired carbon monoxide detectors.
 - A. In the event that the side wall horizontally vented gas fueled equipment is installed in a crawl space or an attic, the hard wired carbon monoxide detector with alarm and battery back-up may be installed on the next adjacent floor level.
 - B. In the event that the requirements of this subdivision can not be met at the time of completion of installation, the owner shall have a period of thirty (30) days to comply with the above requirements; provided, however, that during said thirty (30) day period, a battery operated carbon monoxide detector with an alarm shall be installed.
- 2. Approved carbon monoxide detectors:** Each carbon monoxide detector as required in accordance with the above provisions shall comply with NFPA 720 and be ANSI/UL 2034 listed and IAS certified.
- 3. Signage:** A metal or plastic identification plate shall be permanently mounted to the exterior of the building at a minimum height of eight (8) feet above grade directly in line with the exhaust vent terminal for the horizontally vented gas fueled heating appliance or equipment. The sign shall read, in print size no less than one-half (1/2) inch in size, "GAS VENT DIRECTLY BELOW. KEEP CLEAR OF ALL OBSTRUCTIONS".
- 4. Inspection:** The state or local gas inspector of the side wall horizontally vented gas fueled equipment shall not approve the installation unless, upon inspection, the inspector observes carbon monoxide detectors and signage installed in accordance with the provisions of 248 CMR 5.08(2)(a)1 through 4.
- 5. Product-approved vent/air intake:** A product-approved vent terminal must be used and, if applicable, a product-approved air intake must be used. Installation shall be in strict compliance with the manufacturer's instructions.
- 6. Installation instructions:** A copy of all installation instructions for all Product Approved side wall horizontally vented gas fueled equipment, all venting instructions, all parts lists for venting instructions, and/or all venting design instructions shall remain with the appliance or equipment at the completion of

the installation.

Boiler Sizing

- Check to be sure you have selected the boiler with the proper capacity before continuing the installation. The I=B=R Rating of the boiler selected should be greater than or equal to the calculated peak heating load (heat loss) for the building or area(s) served by the boiler and associated hot water heating systems. See "Table 1: Sea Level Ratings - Natural and Propane Gases" in Section IV of this manual.
- Heat loss calculations should be based on approved industry methods.

Considerations for Boiler Location

Before selecting a location for the boiler, the following should be considered. Each boiler considered for installation must be:

- Supplied with the correct type of gas (natural gas or propane).
- Connected to a suitable combustion air intake piping system to supply the correct amounts of fresh (outdoor) air for combustion (15' minimum equivalent length/100' maximum equivalent length).
- Connected to a suitable venting system to remove the hazardous products of gas combustion (15' minimum equivalent length/100' maximum equivalent length).
- Connected to a suitable hot water heating system.
- Supplied with a suitable electrical supply for all boiler motors and controls.
- Connected to a properly located thermostat or operating control (not included with boiler).
- Placed on level surface (must NOT be installed on carpeting).
- Condensate drain line must be pitched down to floor drain or external condensate pump with reservoir at 1/4" per foot (wood frame or blocks may be used to raise boiler).

Locating the Boiler

1. Select a location which is level, central to the piping systems served and as close to the vent and air intake terminals as possible.
2. Accessibility clearances, if more stringent (i.e. larger clearances) than required fire protection clearances, must be used for the boiler installation. Accessibility clearances may be achieved with the use of removable walls or partitions.
3. The boiler is approved for installation in closets and on combustible floors. This boiler shall NOT be installed on carpeting.

V - BEFORE INSTALLING THE BOILER

4. The clearances shown in **Table 3** indicate required clearances per CSA listing. A minimum 1" clearance must be maintained between combustible construction and each of the right, top and back surfaces of the boiler. Allow at least 24" at the front and left side and 8" at the top for servicing. No combustible clearances are required to venting or combustion air intake piping.

TABLE 3: BOILER CLEARANCES*

Dimension	Combustible Construction	Accessibility/Cleaning	Service
Top	1"	8"	8"
Left Side	1"	24"	24"
Right Side	1"	-	-
Base	1"	-	-
Front	0	24"	24"
Back	6"	-	-
Intake/Vent Piping	0	-	-
Near Boiler Hot Water Piping	1"	-	-

* All distances measured from the cabinet of the boiler.

5. Equipment shall be installed in a location which facilitates the operation of venting and combustion air intake piping systems as described in this manual.
6. Advise owner of boiler to keep venting and combustion air intake passages free of obstructions. Both the venting and combustion air intake piping systems connected to the outdoors must permit flow through the piping systems without restrictions for the boiler to operate.
7. The boiler shall be installed such that the automatic gas ignition system components are protected from water (dripping, spraying, rain, etc.) during operation and service (circulator replacement, control replacement, etc.).
8. The boiler must be located where ambient room temperatures (minimum possible temperatures where boiler is installed assuming boiler is not in operation and therefore contributes no heat to the space) are always at or above 32°F to prevent freezing of liquid condensate.

Combustion Air and Vent Pipe Requirements

This boiler requires a dedicated direct vent system. In a direct vent system, all air for combustion is taken directly from outside atmosphere, and all flue products are discharged to outside atmosphere. Combustion air and vent pipe connections must terminate together in the same atmospheric pressure zone, either through the roof or sidewall (roof termination preferred). See **Figures 1 and 2** for required clearances. If necessary, use of screening no smaller than 1/2" hardware cloth is acceptable.

Figure 1 - Roof Vent/Intake Terminations

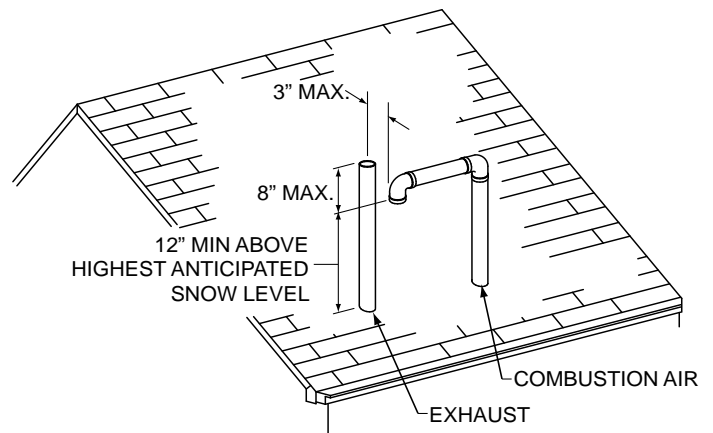
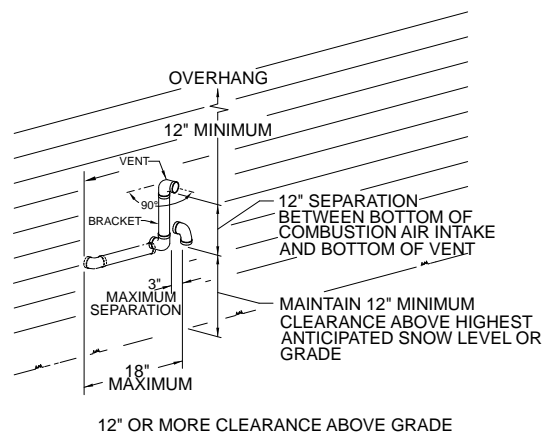
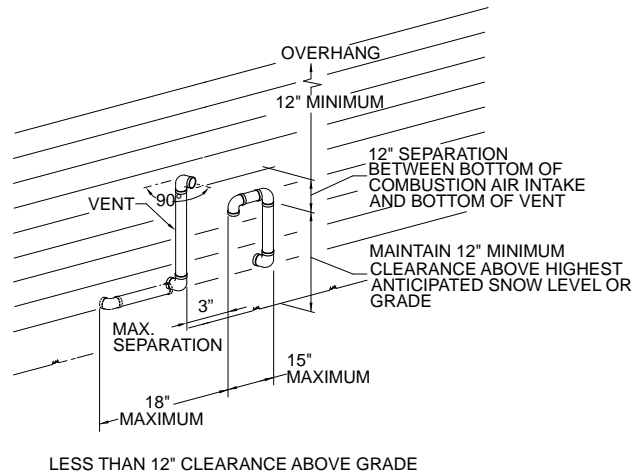

Figure 2 - Sidewall Vent/Intake Terminations



If the concentric vent termination is being used, refer to **Figure 3** for proper setup.

Figure 3 - Concentric Vent Terminations

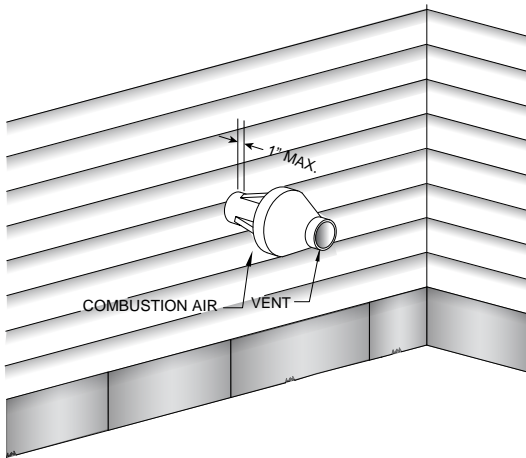
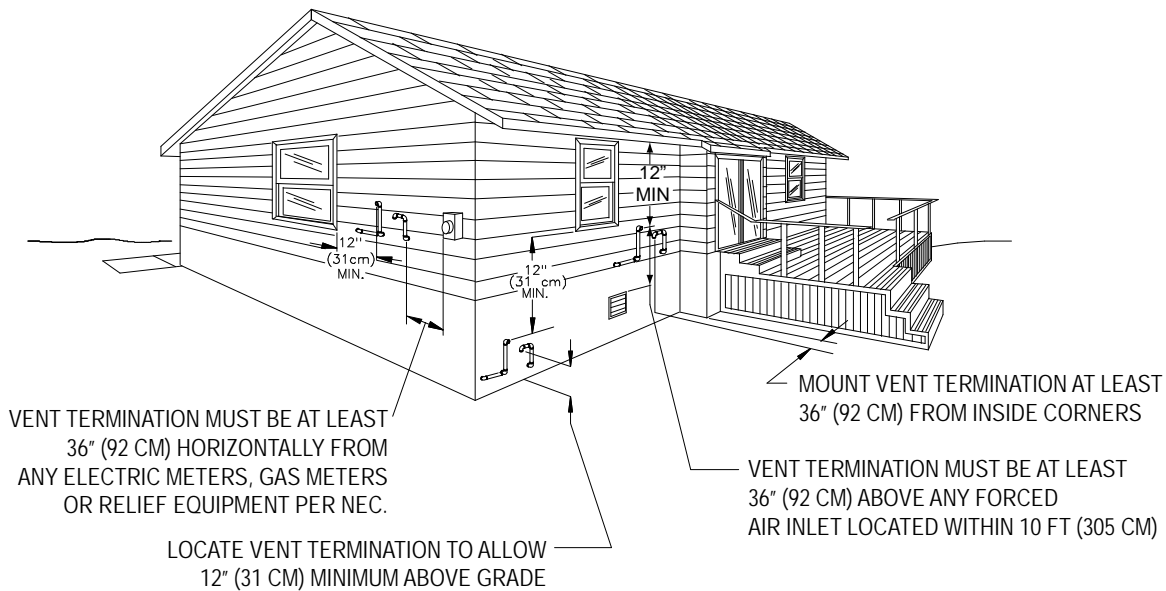

Figure 3A - Clearances To Other Residential Features

NOTE: IF THERE IS A POTENTIAL FOR EXCESSIVE WINDS, SPECIAL CONSIDERATION SHOULD BE GIVEN TO LOCATE THE VENT TERMINATION AWAY FROM THE WINDWARD SIDE OF THE BUILDING.



VENT TERMINATION MUST BE INSTALLED WITH A CLEARANCE OF AT LEAST 12 INCHES (31 CM) FROM ANY AIR OPENING INTO A BUILDING.

Through the wall vents for Category II and IV appliances and non categorized condensing appliances shall not terminate over public walkways or over an area where condensate or vapor could create a nuisance or hazard or could be detrimental to the operation of regulators, relief valves, or other equipment. Where local experience indicates that condensate is a problem with Category I and III appliances, this provision shall also apply.

V - BEFORE INSTALLING THE BOILER

When utilizing two or more boilers, each termination must have at least 12 inches of clearance from any adjacent termination. See diagrams below.

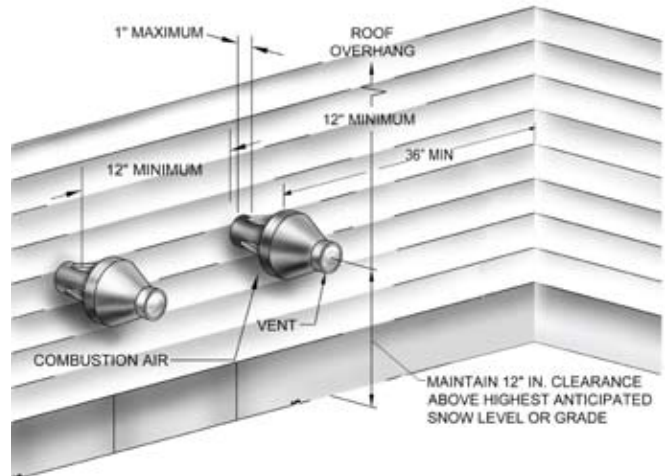
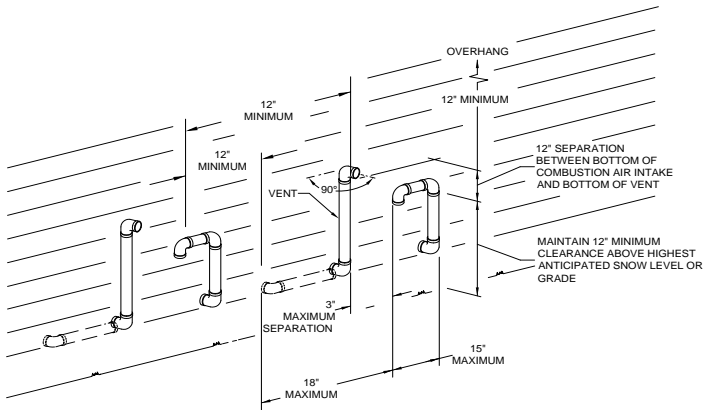

CAUTION

Keep boiler area clean of debris and free of flammable and combustible materials, vapors, and liquids.



WARNING

Failure to follow these warnings could result in fire, property damage, personal injury, or death.

When vent pipe is exposed to temperatures below freezing, such as when it passes through an unheated space or when a chimney is used as a chaseway, vent pipe must be insulated with $\frac{1}{2}$ " Armaflex or equivalent. In extremely cold climate areas, use $\frac{3}{4}$ " Armaflex or equivalent.

Combustion air must be clean outdoor air. Combustion air must not be taken from inside the structure because that air is frequently contaminated by halogens, which include fluorides, chlorides, phosphates, bromides and iodides. These elements are found in aerosols, detergents, bleaches, cleaning solvents, salts, air fresheners, paints, adhesives, and other household products.

NOTICE

Condensate trap is integral to the boiler.

Wood frame or concrete blocks may be used to raise the boiler to maintain drain pitch or to be above external condensate pump reservoir.

There is a 115 volt AC receptacle provided on the control panel to provide power for an external condensate pump (if needed).



WARNING

Failure to follow these warnings could result in fire, property damage, personal injury, or death.

Locate combustion air inlet as far away as possible from swimming pool and swimming pool pump house. All combustion air and vent pipes must be airtight and watertight. Combustion air and vent piping must also terminate exactly as shown in Figures 1 and 2. If a concentric vent termination is being used, refer to Figures 3 through 5 for proper setup.

Vent connections serving appliances vented by natural draft shall not be connected into any portion of mechanical draft systems operating under positive pressure.

Solvent cements are combustible. Keep away from heat, sparks, or open flame. Use only in well ventilated areas. Avoid breathing in vapor or allowing contact with skin or eyes.

Figure 4 - Concentric Vent w/ Dimensions

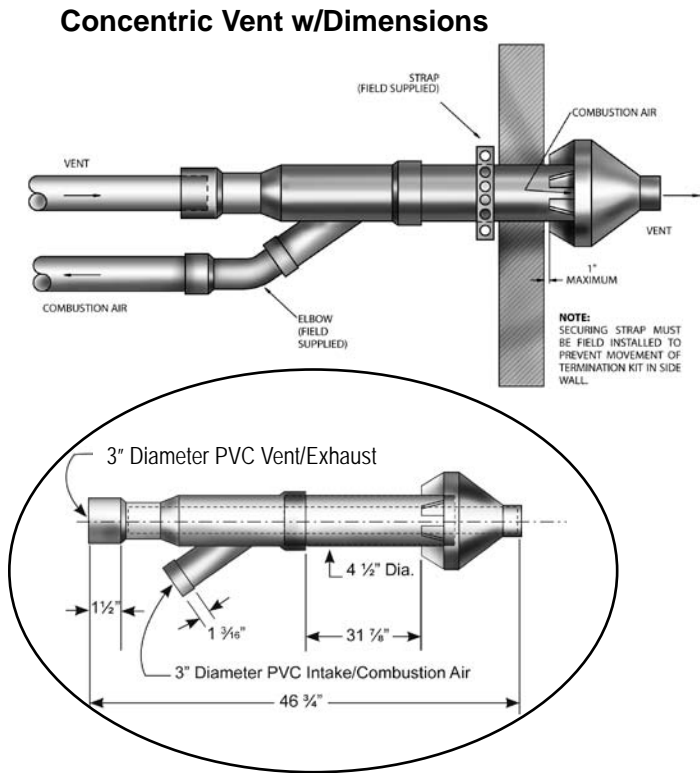
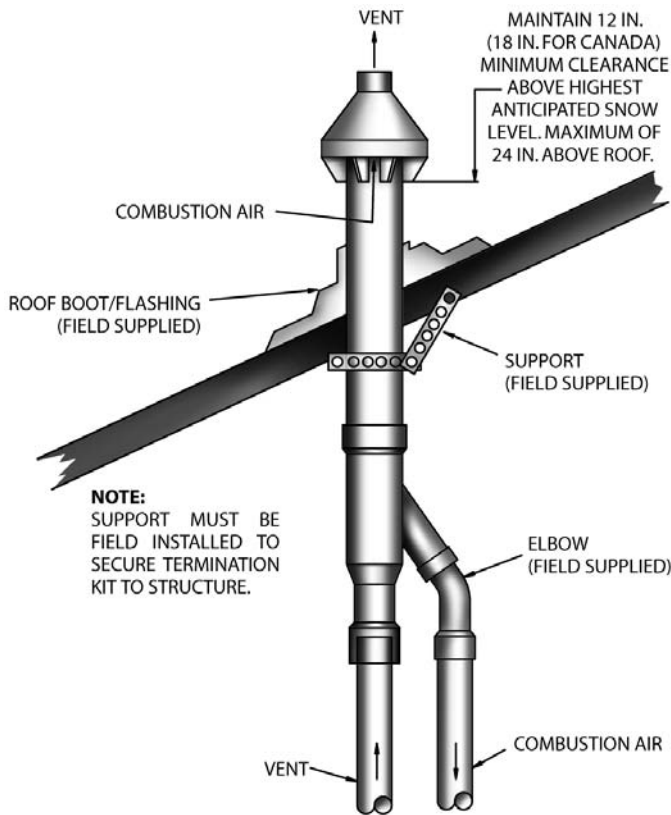

Figure 5 - Concentric Vent Roof Installation



Condensate Drain Requirements

At the rear of the unit a 1/2" PVC pipe nipple with NPT threads is provided for the attachment of the condensate drain line. Attach the 1/2" PVC tee in the parts bag to act as a vent as shown. Attach 1/2" PVC from this point to either a drain or an external condensate pump (not furnished). If the drain level is above the condensate trap, a condensate pump must be used. The condensate pump must be designed for a flue gas condensate application. The condensate drain line must be pitched down to the floor at a minimum of 1/4" per foot and must be routed within the conditioned space to avoid freezing of condensate and blockage of the drain line. If the unit will be started immediately upon completion of installation, prime trap by filling with water until water is seen at the vent.

Foundation Requirements

Boiler must be placed on level surface. Boiler is NOT to be installed on carpeting.

NOTICE

1. If boiler is not level condensate drain lines will not function properly. Adjustable feet are located on the boiler to make up for minor surface irregularities or tilt.
2. Wood frame or blocks may be used to raise boiler to maintain drain pitch or to be above external condensate pump reservoir.

Removal of Existing Boiler From Common Vent System

When an existing boiler is removed from a common venting system, the common venting system is likely to be too large for proper venting of the appliances remaining connected to it. At the time of removal of an existing boiler, the following steps shall be followed with each appliance remaining connected to the common venting system placed in operation, while the other appliances remaining connected to the common venting system are not in operation.

1. Seal any unused openings in the common venting system.
2. Visually inspect the venting system for proper size and horizontal pitch and determine there is no blockage or restrictions, leakage, corrosion and other deficiencies which could cause an unsafe condition.
3. When it is practical, close all building doors and windows and all doors between the space in which the appliances remaining connected to the common venting system are located and other spaces of the building. Turn on clothes dryer and any appliance not connected to the common venting system. Turn on any exhaust fans, such as range hoods and bathroom exhaust, so they will operate at maximum speed. Do not operate a summer

V - BEFORE INSTALLING THE BOILER

exhaust fan. Close fireplace dampers.

- Place in operation the appliance being inspected. Follow the lighting instructions. Adjust thermostat so appliances will operate continuously.
- After it has been determined that each appliance remaining connected to the common venting system properly vents when tested as outlined above, return doors, windows, exhaust fans and any other gas-burning appliance to their previous condition of use.
- Any improper operation of the common venting system should be corrected so the installation conforms with the National Fuel Code, NFPA-54/ANSI-Z223.1-latest revision, or section 5 of CSA-B149 for Canadian standards. When resizing any portion of the common venting system, the common venting system should be resized to approach the minimum size as determined using the appropriate tables in the National Fuel Gas Code, NFPA-54/ANSI-Z223.1-latest revision, or section 5 of CSA-B149 for Canadian standards.

VI - PLACING THE BOILER



WARNING

The boiler must be located on a surface that can support the weight of the installed boiler.

The boiler should be placed to provide the most direct connections to the combustion air, vent and system piping as possible.

Place crated boiler as close to selected location as possible and uncrate boiler. The uncrated boiler may be moved into position

with an appliance dolly or 2-wheel hand truck. The dolly or hand truck should be inserted under the right hand side of the boiler. It is possible to slide the boiler for a short distance on a smooth floor or surface.

NOTICE

NOTE: Refer to "Locating The Boiler" in Section V of this manual for required clearances for servicing and maintenance.

VII - NEAR BOILER PIPING

NOTICE

IMPORTANT: For piping examples using the Gas-Fired Direct Vent Modulating Hot Water Boiler, see the Piping Appendix in Section XVI of this manual. and operation.

Expansion Tank & Make-up Water



CAUTION

Non-potable water only piped directly to boiler. DO NOT connect drinking water to heating system.

CAUTION

Copper supply and return piping must NOT be installed directly into aluminum boiler section castings due to galvanic corrosion between dissimilar metals. Iron or steel bushings or pipe nipples should be used between copper system piping and boiler to make final connection to boiler. Also, the use of dielectric unions is acceptable. The packaged boiler is furnished with iron piping where necessary for the supply and return connections.

When the installation of the boiler is for a new heating system, first install all of the radiation units (panels, radiators, baseboard, or tubing) and the supply and return mains. After all heating system piping and components have been installed, make final connection of the system piping to the boiler.

According to code, a hot water boiler installed above radiation level must be equipped with a low water cut off device. A periodic inspection is necessary, as is flushing of float type devices, per low water cut off manufacturers specific instructions. **This boiler is factory equipped with a manual reset probe-type low water cut off.**

Determine required system fill pressure, system design temperature, and system water content. Boiler contains 2.6 gallons (US). Size expansion tank accordingly. Consult expansion tank manufacturer for proper sizing information. Connect properly sized expansion tank (not furnished) as shown in Figure 6 for diaphragm type expansion tank. For diaphragm type expansion tanks, adjust the tank air pressure to match the system fill pressure. Install air vent (furnished) as shown for diaphragm type expansion tank system only. Install make-up water connections as shown and per local codes. If a pressure reducing valve is used, adjust to match the system fill pressure. In connecting the cold make-up water supply to the boiler, make sure that clean water supply is available. When the water supply is from a well or pump, a sand strainer should be installed at the pump.

Figure 6 - Diaphragm Type Expansion Tank Piping

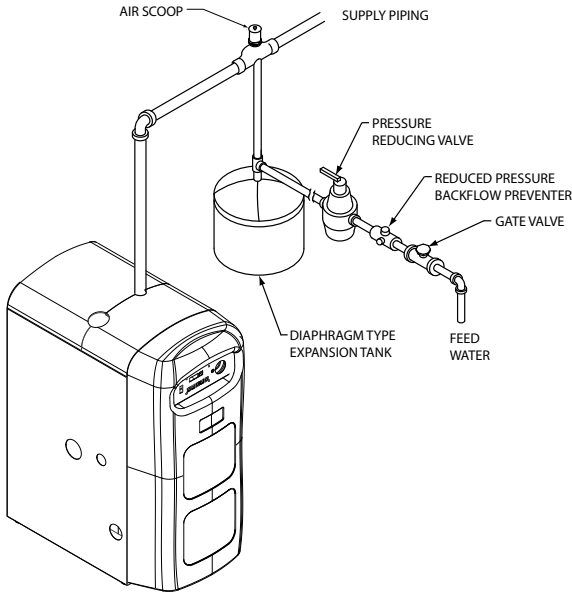

Pressure Relief Valve / Temperature Pressure Gauge

The boiler is furnished with a relief valve in the boiler parts bag. Provide 3/4" piping from the supplied relief valve to a local floor drain, but leave an air gap between piping and drain. No shutoff of any description shall be placed between safety relief valve and the boiler, or on the discharge pipes between such safety valve and the atmosphere. Installation of the safety relief valve shall conform to ANSI/ASME Boiler and Pressure Vessel Code, Section IV. The manufacturer is not responsible for any water damage. Check local codes for maximum height from discharge piping to floor.

Supply & Return Lines

The packaged boiler unit is set up to receive 1 1/4" NPT return piping from the rear of the unit with an option for left or right return connections. 1 1/4" NPT supply piping exits the boiler jacket at the top of the unit.

CAUTION



NOTE: On some boilers the circulator pump and isolation valves are furnished in a carton inside the boiler cabinet and can be installed at the installer preferred location.

Condensate Drain Piping

The condensate trap is integral to the boiler. Use the supplied 1/2" PVC tee, then transition to 1/2" pipe and fittings for PVC condensate drain line. Condensate drain line to be pitched down to floor drain at a minimum of 1/4" per foot.

The 1/2" diameter schedule 40 PVC condensate drain piping and pipe fittings must conform to ANSI standards and ASTM D1785. Schedule 40 PVC cement and primer must conform to ASTM D2564. In Canada, use CSA or ULC certified schedule 40 PVC drain pipe and cement.

A condensate pump with a reservoir (not furnished) may be used to remove condensate to a drain line (sanitary line) above boiler if a floor drain is not available or is inaccessible.

Filling the Condensate Trap with Water

NOTICE

IMPORTANT: On initial start up the condensate trap must be manually filled with water.

The following are the steps required to initially fill the condensate trap for start up, these steps are only required at the initial start up or if maintenance requires draining of the condensate trap:

1. Pour about 1 cup of cold tap water into the vent drain line using the 1/2" PVC vent tee provided with the boiler.

Figure 7 - Relief Valve Discharge Piping

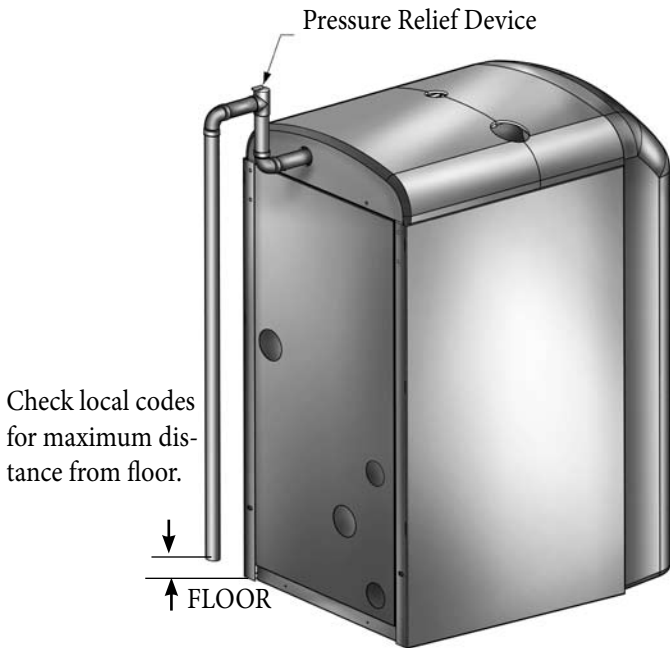

VII - NEAR BOILER PIPING

2. Excess water should go through the overflow and out through the condensate drain line. Verify proper operation of the drain line (or external condensate pump if used).
3. Reinstall the vent drain line.

Chilled Water Piping

The boiler, when used in connection with a refrigeration system,

must be installed so the chiller medium is piped in parallel with the boiler with appropriate valves to prevent the chilled medium from entering the boiler.

The boiler piping system of a hot water boiler connected to heating coils located in air handling units where they may be exposed to refrigerated air circulation must be equipped with flow control valves or other automatic means to prevent gravity circulation of the boiler water during cooling cycle.

VIII - COMBUSTION AIR AND VENT PIPE

Connections & Terminations

For boilers connected to gas vents or chimneys, vent installations shall be in accordance with Venting Requirements of the National Fuel Gas Code, ANSI Z223.1-latest revision, CSA-B149.1 and B149.2, and applicable provisions of the local building codes.

Provisions for combustion and ventilation air must be in accordance with the National Fuel Gas Code, ANSI Z223.1-latest revision, CSA-B149.1 and B149.2, or applicable provisions of the local building code.

These boilers require a dedicated direct vent system. All air for combustion is taken directly from outdoors through the combustion air intake pipe. All flue products are discharged to the outdoors through the vent pipe. Insulate lengths of combustion pipe in unconditioned areas.

1. See Figures 1 through 5 for combustion air and vent pipe roof and sidewall termination (roof termination is preferred). Combustion air and vent pipes must terminate **together in same atmospheric pressure zone as shown**. Construction through which vent and air intake pipes may be installed is a maximum 24" and a minimum ¼" thickness.
2. Combustion air and vent pipe fittings must conform to American National Standards Institute (ANSI) standards and American Society for Testing and Materials (ASTM) standards D1784 (schedule-40 CPVC), D1785 (schedule-40 PVC), D2665 (PVC-DWV), D2241 (SDR-21 and SDR-26 PVC), D2661 (ABS-DWV), or F628 (schedule-40 ABS). Pipe cement and primer must conform to ASTM standards D2564 (PVC) or D2235 (ABS).
3. For Canadian installations all plastic venting material must be listed to ULC S636.



WARNING

Do not use cellular core PVC for venting flue gas.

4. Combustion air and vent pipe connections on boiler are 2" but must increase to 3". Due to potential for flue gas temperatures above 155°F, the first 30" of supplied vent pipe is CPVC while the remaining vent pipe can be PVC. Any replacement of the first 30" of vent pipe must be made with CPVC.

NOTICE

NOTE: The exhaust transition from 2" pipe to 3" pipe must be made in a vertical run. Transition pieces are not included. (See Figure 8 for details.)

Combustion and Vent Piping Length

TABLE #4	Maximum Allowable Temperatures Of Typical Non-Metallic Vet Material					
	Material	HDT		RTI		Standard
		°F	°C	°F	°C	
PVC	158	70	–	–	ASTM F 891 * ASTM D2665 ** ASTM D1785 ** ASTM D2241 **	
CPVC	210	100	–	–	ASTM D2846 ** ASTM F441 ** ASTM F442 **	
ABS	180	82	–	–	ASTM D2661 *** ASTM F628 ***	
Radel-A200	414	212	–	–	UL-1738 ULC S636	

* Allowable temperatures based on Classifications covered in ASTM D4396 [Deflection Temperatures under Load (264psi) (1819 KPa)].

** Allowable temperatures based on Classifications covered in ASTM D1784 [Deflection Temperatures under Load (264psi) (1819 KPa)].

*** Allowable temperatures based on Classifications covered in ASTM D3965 [Deflection Temperatures under Load(264psi) (1819 KPa)].

3" Pipe Min. Venting	3" Pipe Max. Venting
15 ft. equivalent length	100 ft. equivalent length

The length of pipe is counted from the end of the supplied 2" CPVC pipe exiting the boiler. The termination is not counted in the "Total Equipment Length." The combustion air supply pipe must terminate at the same location as the exhaust pipe.

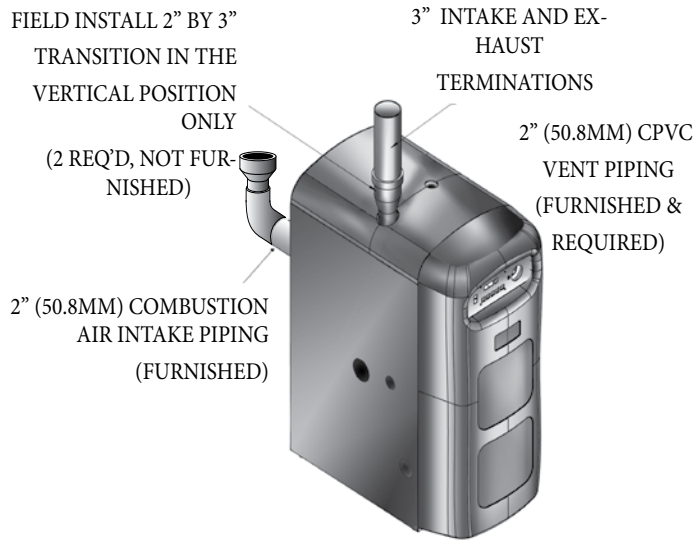
Figure 8 - Combustion Air & Vent Piping

Reduce the maximum vent length by 5' per each 90° elbow.

- Exhaust air piping to be pitched back to boiler at minimum $\frac{1}{4}$ " per foot from vent terminals so that all moisture in vent piping drains to boiler. Pipes must be pitched continuously with no sags or low spots where moisture can accumulate and block the flow of flue gas. Combustion air and vent pipes must be airtight and watertight.
- Consideration for the following should be used when determining an appropriate location for termination of combustion air and vent piping:
 - Comply with all clearances required.
 - Termination should be positioned where vent vapors will not damage plants/shrubs or air conditioning equipment.
 - Termination should be positioned so that it will not be effected by wind eddy, air born leaves, snow, or recirculated flue gases.
 - Termination should be positioned where it will not be subjected to potential damage by foreign objects, such as stones, balls, etc.
 - Termination should be positioned where vent vapors are not objectionable.
 - Put vent on a wall away from the prevailing winter wind. Locate or guard the vent to prevent accidental contact with people or pets.
 - Terminate the vent above normal snow line. Avoid locations where snow may drift and block the vent. Ice or snow may cause the boiler to shut down if the vent becomes obstructed.
 - Under certain conditions, flue gas will condense, forming moisture, and may be corrosive. In such cases, steps

should be taken to prevent building materials at the vent from being damaged by exhaust of flue gas.

- The venting system shall terminate at least 3' above any forced air inlet (except boiler's combustion air inlet) within 10'. The venting system shall terminate at least 12" from any air opening into any building. The bottom of the vent shall be located at least 12" above grade. The vent terminal shall not be installed closer than 3' from the inside corner of an "L" shaped structure. Termination of the vent should be kept at least 3' away from vegetation. The venting system shall terminate at least 4' horizontally from, and in no case above or below, electric meters, gas meters, regulators, and relief equipment, or under a deck or porch.
- Through the wall vents for Category II and IV appliances and non categorized condensing appliances shall not terminate over public walkways or over an area where condensate or vapor could create a nuisance or hazard or could be detrimental to the operation of regulators, relief vales, or other equipment. Where local experience indicates that condensate is a problem with Category I and III appliances, this provision shall also apply. If multiple terminations are used, there must be a minimum of 12" between the exhaust of one termination and the air intake of the next termination. See Figures 1-3 for illustrations.

Installation

NOTICE

IMPORTANT: When transitioning from CPVC to PVC it is recommended to use Weld-On CPVC 724 or other cement approved for CPVC to PVC. In Canada ULC S636 approved cement must be used.

- Attach combustion air intake piping to supplied 2" PVC Intake Connector. Attach vent piping to furnished 2" CPVC vent pipe. Use a 2" x 3" adapter in both air inlet and exhaust.

NOTICE

NOTE: All pipe joints are to be water tight.

- Working from the boiler to the outside, cut pipe to required length(s).
- Deburr inside and outside of pipe, and remove all shavings from pipe.
- Chamfer outside edge of pipe for better distribution of primer and cement.
- Clean and dry all surfaces to be joined.
- Check dry fit of pipe and mark insertion depth on pipe.

VIII - COMBUSTION AIR AND VENT PIPE

NOTICE

NOTE: It is recommended that all pipes be cut, prepared, and pre-assembled before permanently cementing any joint.

- After pipes have been cut and pre-assembled, apply cement primer to pipe fitting socket and end of pipe to insertion mark. Quickly apply approved cement to end of pipe and fitting socket (over primer). Apply cement in light, uniform coat on the inside of socket to prevent buildup of excess cement. Apply second coat.

NOTICE

NOTE: Primer and cement will discolor jacket. Take precautions to protect jacket while cementing vent pipe.

- While cement is still wet, insert pipe into socket with a ¼ turn twist. Be sure pipe is fully inserted into fitting socket.
- Wipe excess cement from joint. A continuous bead of cement will be visible around perimeter of a properly made joint.
- Handle pipe joint carefully until cement sets.
- Support combustion air and vent piping a minimum of every 5' using pre-formed metal hanging straps. Support combustion air and vent piping so no weight is resting on the boiler jacket. Do not rigidly support pipes. Allow movement due to expansion and contraction.
- Slope combustion air and vent pipes toward boiler a minimum of ¼" per linear foot with no sags between hangers.
- Use appropriate methods to seal openings where vent and combustion air pipes pass through roof or side wall.

IX - GAS SUPPLY PIPING

Check Gas Supply

The gas pipe to your boiler must be the correct size for the length of run and for the total BTU per hour input of all gas utilization equipment connected to it. See Table 4 for proper size. Be sure your gas line complies with local codes and gas company requirements.

The boiler and its individual shutoff valve must be disconnected from the gas supply piping system during any pressure testing of that system at test pressures in excess of ½ psig (3.5kPa).

The boiler must be isolated from the gas supply piping system by closing its individual manual shutoff valve during any pressure

testing of the gas supply piping system at test pressures equal to or greater than ½ psig (3.5kPa).

In order for proper operation of the boiler, it is recommended that the line pressure be within the minimum and maximum values in **Table 5**.

TABLE 4: GAS PIPING SIZES

Natural Gas				
Pipe Length	Pipe Capacity - BTU/Hr. Input Includes Fittings			
	½"	¾"	1"	1¼"
20'	92,000	190,000	350,000	625,000
40'	63,000	130,000	245,000	445,000
60'	50,000	105,000	195,000	365,000

LP Gas				
Pipe Length	Pipe Capacity - BTU/Hr. Input Includes Fittings			
	Copper Tubing (O.D.)		Iron Pipe	
	⅝"	¾"	½"	¾"
20'	131,000	216,000	189,000	393,000
40'	90,000	145,000	129,000	267,000
60'	72,000	121,000	103,000	217,000

The length of pipe or tubing should be measured from the gas meter or propane second stage regulator.

TABLE 5: GAS SUPPLY PRESSURE

Natural Gas	4" min. w.c.	10" max. w.c.
LP Gas	10" min. w.c.	14" max. w.c.

Check line pressure while unit is running in high fire mode.

Connecting the Gas Piping

Refer to **Figure 9** for the general layout at the boiler, which shows the basic fittings you will need. As shipped, the gas line enters the boiler through the right side but, as an option, it can be routed through either the rear or left side panel.

Figure 9 - Gas Piping

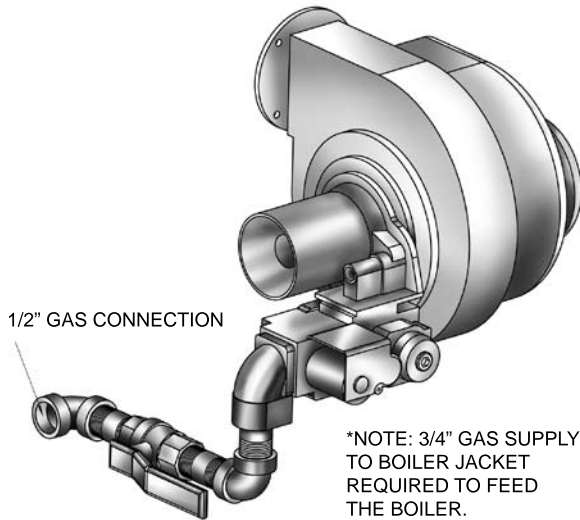

The boiler is equipped with a ½” NPT connection on the gas valve for supply piping and ½” NPT ball valve for manual shut off. The following rules apply for boiler piping:

1. Use only those piping materials and joining methods listed as acceptable by the authority having jurisdiction, or in the absence of such requirements, by the National Fuel Gas Code, ANSI Z223.1- latest revision. In Canada, follow the CAN/CGA B149.1 and .2 Installation Codes for Gas Burning Appliances and Equipment.

2. Use pipe joint compound suitable for liquefied petroleum gas on male threads only.
3. Use ground joint unions.
4. Install a sediment trap upstream of gas controls.
5. Use two pipe wrenches when making the connection to the gas valve to keep it from turning.
6. Install a manual shutoff valve in the vertical pipe about 5’ above floor outside the boiler jacket in addition to the shutoff valve supplied with the boiler.
7. Tighten all joints securely.
8. Propane gas connections should only be made by a licensed propane installer.
9. Two stage regulation should be used by the propane installer.
10. Propane gas piping should be checked out by the propane installer.

Checking the Gas Piping

After all connections have been made, check immediately for leaks. Open the manual shutoff valve. Test for leaks by applying soap suds (or a liquid detergent) to each joint. Bubbles forming indicate leak.

Correct even the smallest leak at once.



WARNING

Never use a match or open flame to test for leaks!!

X - ELECTRICAL WIRING

IMPORTANT: Wiring diagrams for the Gas-Fired Direct Vent Modulating Hot Water Boiler can be found in Section XIV of this manual.



WARNING

For your safety, turn off electrical power supply at service panel before making any electrical connections to avoid possible electric shock hazard. Failure to do so can cause severe personal injury or death.

NOTICE

IMPORTANT: Wiring must be N.E.C. Class 1. If original boiler wiring must be replaced, use only type 105°C wire or equivalent. Boiler must be electrically grounded as required by National Electrical Code ANSI/NFPA 70 - latest edition, and operation.

Codes

Installations must comply with National Electrical Code, any other national, state, provincial, or local codes or regulations, and, in Canada, with CSA C22.1 Canadian Electrical Code (Part 1) and any local codes. (L1, L2)

Line Voltage Connections

1. Connect 120 VAC power wiring to line voltage terminal strip on boiler control panel.
2. Provide and install a fused disconnect or service switch (15 amp recommended) as required by code.
3. Boiler circulator is shipped loose. Wire boiler circulator as shown in wire diagram label on boiler side panel. (CH L1, CH L2) CH = Control Heat
4. When connecting a DHW circulator, connect wiring to line voltage terminal strip on boiler control panel. (DHW L1, DHW L2) DHW = Domestic Hot Water

- Route all wires and conduits to the openings in the right jacket panel.

Line Voltage Monitor

This boiler is factory equipped with a line voltage monitor that continuously monitors incoming voltage for errors. When incoming line voltage is greater than 12% or less than 8% of the nominal voltage monitor will flash indicating a fault. Ten minutes after the line voltage is back within the acceptable range the green light will illuminate on the monitor and the boiler will restart. The line voltage monitor is factory set at 115VAC. It is important that the monitor be set to the voltage that is present at the installation site by following these directions:

- Using a multimeter, locate the wall outlet nearest to the boiler and determine the line voltage present on site.
- Disconnect power to the boiler.
- Remove the boiler cover.
- Locate the line voltage monitor mounted to the display panel.
- Remove line monitor protective cover.
- Using a small screwdriver turn the left dial until the arrow points at the input voltage measured during step 1.
- The right dial should be set at 0.1 minutes, this is the factory setting.
- Reinstall line monitor protective cover.
- Replace boiler cover and re-connect power to the unit.

Low Voltage Connections

- Connect low voltage wiring to low voltage terminal strip as shown in the boiler wiring diagram.
- Route all low voltage wires through opening on the right jacket panel. Use shielded cable.

Thermostat

- Connect room thermostat or end switch (isolated contact only) between terminals T1 and T2.
- Install thermostat on inside wall away from influences of drafts, hot or cold water pipes, lighting fixtures, televisions, sun rays, or fireplaces.
- Thermostat anticipator (if applicable):
 - If connected directly to boiler, set for 0.1 amps.
 - If connected to relays or other devices, set to match total electrical power requirements of connected devices. See device manufacturers' specifications and thermostat instructions for details.

Outdoor Temperature Sensor

- Connect outdoor temperature sensor between terminals A1 and A2 to enable outdoor reset operation of the boiler. If fixed temperature operation is required, do not install outdoor sensor.
- Mount sensor on exterior wall, shielded from direct sunlight or flow of heat or cooling from other sources.
- If desired, install a summer/winter switch across terminals A1 and A2. When the switch is closed, the boiler (space heating) circulator is disabled.
- Route sensor wires through the holes provided on the right jacket panel of the boiler.

DHW Aquastat

Connect storage indirect water heater (DHW) aquastat between terminals DHW T1 and DHW T2.

Figure 10 - Line Voltage Monitor



This section provides a brief description of the key controls and accessories found in this boiler. See the Repair Parts Manual (P/N# 240006107) for illustrations and the Control Manual and Operation Instructions (P/N# 240006104) for a detailed sequence of operation and troubleshooting procedures.

Aluminum Heat Exchanger

This appliance employs a cast aluminum heat exchanger that features a monoblock design. The monoblock design eliminates the need for mating sections and therefore eliminates leaks between sections. Since the heat exchanger is cast of aluminum instead of iron, it has better heat transfer properties which in turn lead to higher efficiency and cooler exhaust temperatures. These cooler exhaust temperatures create condensation of the flue gas, which would cause corrosion in traditional cast iron heat exchangers.

Main Power Switch

This appliance features a main power switch located on the display panel. The main power switch is illuminated when it is receiving power and in the ON position. The only time that the switch should not be illuminated once the boiler is ready for use is when the switch is in the OFF position.

Modulating Boiler Control

This appliance incorporates an integrated modulating control that senses the load necessary to heat a structure and therefore uses less fuel than a conventional fixed firing rate boiler when there is a lower than peak demand for heat. The control senses the supply water, return water, and outside air temperatures if the outside air sensor is connected and calculates the load on the system. It then adjusts the firing rate to deliver the amount of heat that is needed at that particular time.

NTC Sensors

The NTC sensors used with this appliance for measuring supply water, return water, and outside air temperature are specially configured to operate with the modulating boiler control.

Modulating Blower

The modulating blower provides a means of introducing the gas/air mixture through the burner and into the combustion chamber where combustion can begin and then out the exhaust vent where the combustion products are discharged to the outdoors. The blower is designed to communicate with the modulating control to run at variable speeds dependent on the heat load experienced by the heating system. The variable speeds create pressures felt by the gas valve and gas/air mixer that dictate how much fuel is introduced to the combustion process.

Gas Control Valve

The gas controls in this boiler have been developed for domestic heating appliances with premix burners and automatic direct burner ignition and are suitable for natural and LP gas. The gas controls perform all the functions required to safely regulate gas flow to the main burner of the boiler. The gas valve is directly connected to the gas/air mixer.

Gas/Air Mixer

The venturi design of the gas/air ensures that there is always the correct mixture of air and gas.

Modulating Burner

This burner is designed to operate over the full range of input for this boiler. The burner can operate under normal (blue flame) and infrared conditions.

Direct Spark Igniter (DSI)

This appliance uses a DSI to ignite the fuel/air mixture in the combustion chamber and sense flame during operation. The DSI is a durable, reliable component that resists breakage due to handling or inadvertent impact with other objects.

Manual Reset Low Water Cut Off

This appliance employs a factory installed integral low water cut off (LWCO) that has to be manually reset if there is a low water

condition. The LWCO senses water through a probe at the top of the boiler that sends a signal through the water to ground. If the signal is not sensed through the ground, the LWCO enters a lockout mode that disables the appliance. If the LWCO is in normal mode a red indicator light is illuminated on the LWCO panel in the boiler. During a low water condition, the red light goes out and the LWCO and control reset buttons on the display panel must be depressed to reset the LWCO.

Normally Closed LWCO Switch

This round button switch located next to the digital display is normally closed and spring loaded so that, when depressed, it opens, and closes again when pressure is removed. The switch is used as the manual reset for the LWCO. When tripped the LWCO will remain in lockout until the water level reaches the probe and the switch is depressed to an open state and then released to a closed state, which sends a signal to the LWCO to resume normal operation. The boiler control reset button must then be pressed to reset from a low water condition. The LWCO switch and control reset button are located on the display panel of the boiler.

High Limit Aquastat Control

The high limit aquastat control is a redundant safety limit control that provides a means for protecting the boiler and heating system from unsafe operating conditions which could damage the boiler. The aquastat is mounted in the 1/2" NPT control well and 3/4" X 1/2" bushing on the top of the front boiler section at the hot water outlet. The aquastat is tied in with the boiler control and is factory set at 200°F water temperature. The high limit setpoint is field adjustable and may be set anywhere between 100°F and 200°F, with the maximum high limit setpoint not exceeding 200°F. The field high limit setpoint adjustment for each installation depends on heating system requirements. The aquastat automatically resets when the boiler water temperature decreases ten degrees below the high limit setpoint value. (Adjustable differential from 5°F to 30°F)

NOTICE

NOTE: Boiler operating temperature (temperature curve) is calculated and set in the parameters of the boiler control.

Casting Temperature Safety Switch

In the event of lack of or loss of water in the boiler, the casting temperature safety switch (230°F setpoint) installed on the top of the aluminum boiler section behind the supply piping shuts off the boiler by shutting off power to the boiler control and causes a failure code to be displayed on the digital readout. This fault requires manual reset of the casting temperature safety switch to restart the boiler and the reset to be pressed on the user interface panel. Verify that the boiler is properly filled with water and no air is trapped in the top of the casting (check cap on Cam Vent at the heat exchanger)

before resetting this switch.

Taco Pump Curve

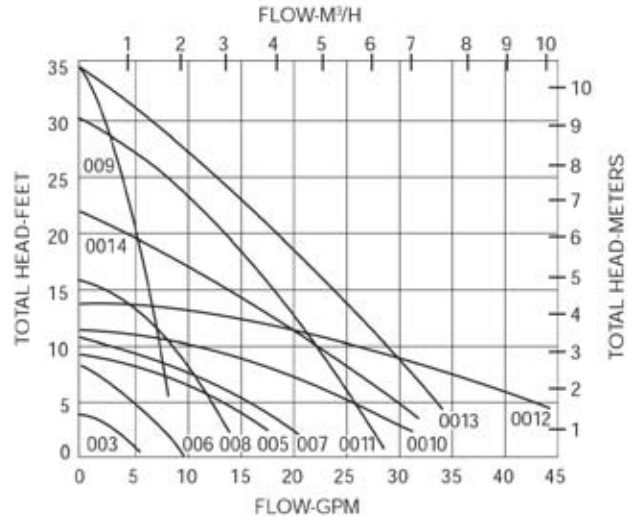

Grundfos Pump Curve

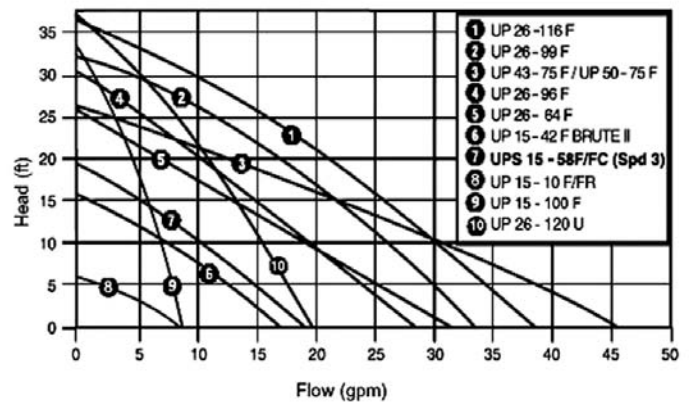

Bell & Gossett Pump Curve

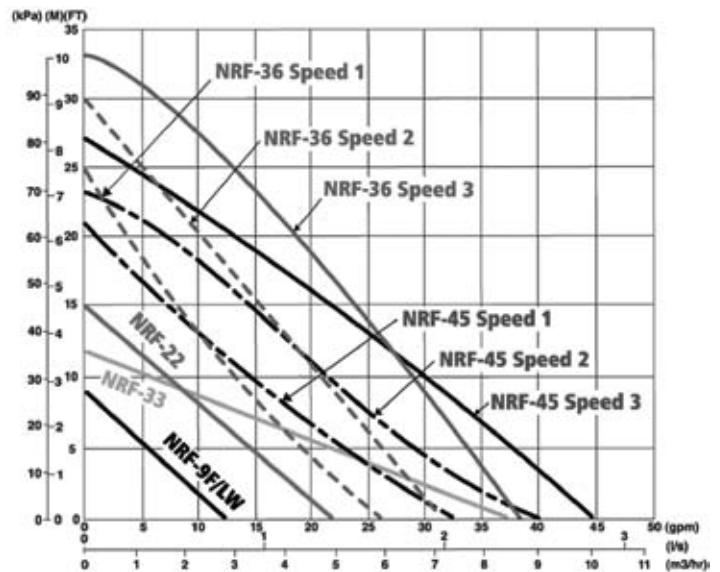



WARNING

Never run cold water into a hot, empty boiler.

Circulator Pump

Every forced hot water system requires at least one circulating pump. The circulating pump imparts the necessary energy to move water through the closed loop supply and return piping systems, terminal heating equipment (finned tube radiators, etc.) and back through the boiler for reheating. To provide the required hot water flow rates, the circulator pump must be properly sized to overcome frictional losses (usually measured in feet of water, also referred to as “pump head loss”) of the supply and return piping systems and boiler. The circulator pump is furnished in a carton within the boiler cabinet. The circulator(s) should always be located on the downstream (“pumping away”) side of the expansion tank.

Air Proving Blocked Vent Safety Assembly

The air proving blocked vent safety assembly incorporates two pressure switches that are designed to discontinue operation of the appliance if there is a problem with the blower or venting system. The normally open switch closes upon the initiation of the blower and functions as an air proving switch. The normally closed switch opens if there is a blockage in the combustion air intake or exhaust vent pipes.

Drain Valve

The manual drain valve provides a means of draining the water in the heating system, including the boiler and hot water supply and return piping systems installed above the drain valve. This drain valve is installed in the return piping at the bottom front of the boiler section. Any piping installed below the elevation of this drain valve will require additional drain valves to be installed at low points in the piping systems in order to drain the entire system.

ASME Rated Pressure Relief Valve

Each boiler must have a properly sized and installed American Society of Mechanical Engineers (ASME) rated pressure relief valve. Water expands as it is heated by the burner/boiler sections. If there is no place for the water to expand its volume, (i.e., a properly sized and properly functioning expansion tank) pressure on the inside of the boiler and heating system will increase. The furnished relief valve will automatically open at 30 psig pressure to relieve the strain on the boiler and heating system from the increasing pressure. The pressure relief valve discharge must be piped with the same size pipe as the valve discharge opening to an open drain, tub or sink, or other suitable drainage point not subject to freezing, in accordance with ASME specifications. Failure to provide the pressure relief valve with piping as herein described may cause water damage and/or serious bodily injury. The boiler manufacturer is not responsible for any water damage or personal injury. Check local codes for maximum discharge height from floor.

External Condensate Pump (optional)

For installations where there is no floor drain or other appropriate drainage receptacle available to receive condensate from the boiler, an external float activated condensate pump with integral sump is required. The condensate pump can be piped to a remote tie in point to a sanitary sewer system. For this application, the boiler must be installed so that proper pitch of piping to the external condensate reservoir (sump) can be accomplished. Use wood frame or concrete blocks to raise boiler as required for proper installation.

Concentric Vent/Air Intake Termination (Optional)

The optional concentric vent/air intake termination utilizes a single opening per each appliance through the wall or roof of a structure.

XII - WATER TREATMENT & FREEZE PROTECTION

When filling the boiler water is the preferred heating solution. Most potable water supplies may be used to charge and re-fill provided the chlorine and chloride ions levels are less than 100 ppm.

Antifreeze may be used in most applications provided all of the following conditions are met:

1. Unless a strict schedule of sampling, analysis and maintenance of the antifreeze solution is followed, the boiler must be piped as a primary loop connected to secondary loop as shown in the Piping & Wiring Diagram Appendix. Failure to perform regular maintenance to the antifreeze manufacturer’s instructions will result in damage to the heat exchanger and the voiding of boiler warranty.
2. Only the antifreeze manufacturers listed below are selected.

3. At installation of a new or replacement boiler and at least on an annual basis the system antifreeze must be analyzed by the antifreeze supplier or their recommended laboratory.
4. Adjustments to the system antifreeze must be made according to the antifreeze manufacturers recommendations using only their recommended products.
5. All existing systems MUST be flushed of ALL old system fluid. Failure to do so may void the boiler warranty if evidence of improper flushing is revealed.

Consult with your heating professional for recommendations.

Piping Recommendations

- System leaks may not always be visible. An unseen system

leak will become obvious if boiler pressure decreases when make up valve is closed.

- All system leaks must be repaired immediately. Constant introduction of make up water will introduce dissolved oxygen, resulting in accelerated boiler corrosion.
- It is recommended that Primary/Secondary piping be used with any of the recommended antifreeze solutions found in this manual. See the **Piping & Wiring Diagram Appendix**.

Water Chemistry:

- This boiler is designed for a closed loop hydronic heat system ONLY! This boiler is not suitable for natural gravity type installations, or any other open type system.
- System fluid pH must be maintained between 7.0 and 8.0.
- Maintain water hardness below 7 grains hardness.
- Filling with chlorinated fresh water should be acceptable since drinking water chlorine levels are typically less than 5 ppm. Do not fill boiler with water containing chlorine and chloride ions levels greater than 100 ppm.
- Do not use inhibitors or other additives that are not specifically approved by the antifreeze manufacturer for this product.
- Consult the antifreeze manufacturer if any of the above are outside the stated ranges.

Cleaning the Hydronic System:

NOTICE

IMPORTANT: Do not mix different manufacturers' products. Doing so will void the warranty of the boiler.

Consideration MUST be given to cleaning the heating system, particularly in retrofit situations where a new boiler with an aluminum heat exchanger is being installed in an existing piping system.

All existing systems must be cleaned and flushed according to the antifreeze manufacturer's recommendations.

Systems that have antifreeze that is not recommended by the boiler manufacturer must be completely flushed to ensure no unapproved antifreeze remains according to the recommended antifreeze manufacturer's recommendations. Evidence of an alternate antifreeze in the system may void the boiler warranty.

In older systems obviously discolored, murky or dirty water; or a pH reading outside the boiler manufacturer's stated acceptable range (pH 7.0 to 8.0) are indications that the system should be cleaned or treated.

1. Measure total capacity of the system including the piping, tanks, boiler, collector plates, etc. The most accurate method of measuring fluid capacity is to fill the system and then completely drain it, volumetrically measuring the fluid drained.
2. Thoroughly flush the system with clean water to remove any sediment or contaminants. Sludge and iron oxide deposits can cause rapid breakdown of inhibitors.
3. Cleaning fluid – Flushing with clean water is preferred. If cleaning fluid is used, only use cleaner specifically approved for use with aluminum boilers. Use only cleaning fluids and the procedure recommended by the antifreeze manufacturer.

Freeze Protection

Aluminum Safe Antifreeze, Treatments and Additive Guidelines:

Antifreeze, if required, must be one of the antifreeze manufacturers listed in this manual. See the "Recommended Aluminum Antifreeze & Inhibitor Suppliers" section of this manual for a list of boiler manufacturer approved products.

- Always clean system prior to using antifreeze, refer to the Cleaning the Hydronic System section of this manual for details.
- Only use the antifreeze manufacturers' products outlined in this document.
- Use of antifreeze must be in accordance with local plumbing codes.
- Dispose of old antifreeze and boiler system water in accordance with local authorities.
- **Antifreeze will raise the pH of the hydronic solution in a heating system above the recommended level due to the corrosion inhibitors in the antifreeze.** The solution must be treated to maintain a pH within the boiler manufacturer's recommended level to avoid damage to the heat exchanger. Follow antifreeze manufacturer's instructions for details on how to adjust the pH.
- If the system has leaked for some reason, the water and antifreeze chemistry will need to be adjusted. To avoid damage to the boiler, check the pH and chemistry of the boiler solution and consult the antifreeze manufacturer for recommendations.
- It is recommended that a pH reading is taken annually, and adjusted as necessary. Follow antifreeze / inhibitor manufacturer's instructions for details on how to adjust the pH.

XII - WATER TREATMENT & FREEZE PROTECTION

NOTICE

Antifreeze solutions can breakdown over time. Failure to check antifreeze chemistry, including inhibitors, annually may result in accelerated corrosion of boiler and other system components. Consult with the antifreeze manufacturer for recommendations.

- Use of antifreeze in any boiler will reduce heating capacity as much as 10-20%. This must be taken into consideration when sizing the heating system, pumps and expansion tank. Consult antifreeze manufacturer's literature for specific information on reduced capacity.

- Using the antifreeze manufacturer's instructions to determine the freezing temperature needed and use the correct amount of antifreeze. Never exceed 50% antifreeze by volume.
- The boiler operating pressure must remain below 15 psi for antifreeze solutions that specify a maximum of 250°F (121°C).

Recommended Aluminum Antifreeze & Inhibitor Suppliers	Recommended Products
Interstate Chemical 2797 Freedland Road P.O. Box 1600 Hermitage, PA 16148-0600 www.interstatechemical.com Tel: 800-422-2436 Fax: 724-981-8383	Intercool NFP-30,40,50 AA Intercool RPH-15*
Noble Company PO Box 350 Grand Haven, MI 49417 www.noblecompany.com Tel: 800-878-5788 Fax: 800-272-1519	Noburst AL Antifreeze
Rhomar Water Management, Inc. PO Box 229 Springfield, MO 65801 www.rhomarwater.com Tel: 800-543-5975 Fax: 417-862-6410	Rhogard Antifreeze Pro-Tek 922 Inhibitor*

* These products may be used to adjust the pH level of the hydronic system, but on occasion may not resolve the pH issue. In these cases it is recommended to flush the system and refill with untreated water and new boiler manufacturer approved antifreeze suitable for Aluminum heat exchangers.

IMPORTANT: Regardless of antifreeze or inhibitors used, be sure to follow the antifreeze manufacturer's instructions for use, safe handling and storage of their products. Refer to the MSDS (Material Safety Data Sheets) provided by the antifreeze manufacturer for potential hazards and first aid procedures for exposure or ingestion.

Antifreeze Testing Services: Each of the recommended antifreeze manufacturers have developed a sampling program available to the homeowner and contractor. Contact the antifreeze manufacturer regarding their sampling plan procedure. Consult the antifreeze manufacturer for details on sample requirements and recommendations.

The boiler manufacturer reserves the right to make changes without notice.

Filling boiler with water and purging air

For each of the following systems, refer to the appropriate piping diagrams in the Installation Manual

1. Systems With Diaphragm Type Expansion Tanks

- A. Close all zone service valves on the supply and return piping. Open the feed valve and fill boiler with water. Make sure air vent is open. Hold relief valve open until water runs air free for five seconds to rapidly bleed air from boiler, then let the relief valve snap shut.
- B. Open the zone service valve on the supply pipe for the first zone. Open the purge valve on the first zone. Feed water will fill the zone, pushing air out the purge valve. Close the purge valve when the water runs air free. Close the zone service valve.
- C. Repeat step 2 for all remaining zones.
- D. Open all service valves. Any air remaining trapped in the return lines between the service valves and the boiler will be pushed towards the air vent when the boiler is placed in operation.
- E. Inspect piping system and repair any leaks immediately.

2. Systems With Conventional Closed Type Expansion Tanks

- A. Close all zone service valves on the supply and return piping and close the expansion tank service valve. Drain expansion tank. Open the feed valve and fill boiler with water. Hold relief valve open until water runs air free for five seconds to rapidly bleed air from boiler, then let the relief valve snap shut.
- B. Open the zone service valve on the supply pipe for the first zone. Open the purge valve on the first zone. Feed water will fill the zone, pushing air out the purge valve. Close the purge valve when the water runs air free. Close the zone service valve.
- C. Repeat step 2 for all remaining zones.
- D. Open the expansion tank service valve and the tank vent. Fill the tank to the proper level and close the tank vent. Remove the handle from the expansion tank service valve so the homeowner doesn't accidentally close it.
- E. Open all service valves. Any air remaining trapped in the return lines between the service valves and the boiler will be pushed towards the expansion tank when the boiler is placed in operation.
- F. Inspect piping system. Repair any leaks immediately.

NOTICE

NOTE: Do not use stop leak compounds. Leaks in threaded connections in the aluminum boiler sections must be repaired immediately. Aluminum threads will not seal themselves.

LIGHTING INSTRUCTIONS FOR YOUR SAFETY READ BEFORE OPERATING!!

WARNING



If you do not follow these instructions exactly, a fire or explosion may result causing property damage, personal injury or loss of life.

1. This appliance does not have a pilot. It is equipped with an ignition device which automatically lights the burner. Do not try to light this burner by hand!!
2. Before operating smell all around the appliance area for gas. Be sure to smell next to the floor because propane gas is heavier than air and will settle to the floor.

CAUTION

WHAT TO DO IF YOU SMELL GAS

Do not try to light any appliance.



Do not touch any electrical switches; do not use any phones in your building.

Immediately call your gas supplier from a neighbor's phone. Follow the gas supplier's instructions. If you cannot reach your gas supplier, call the fire department.

3. Use only your hand to turn the gas ball valve. Never use tools. If the valve will not turn by hand, do not try to repair it, call a qualified service technician. Force or attempted repair may cause fire or explosion.
4. Do not use this appliance if any part has been under water. Immediately call a qualified service technician to inspect the appliance and to replace any part of the control system and any gas control which has been under water.

OPERATING INSTRUCTIONS

NOTICE

STOP! Read the safety information above before operating this appliance.

1. Set the thermostat to the lowest setting.
2. Turn off all electrical power to the appliance.
3. This appliance does not have a pilot. It is equipped with an ignition device which automatically lights the burner. Do not try to light this burner by hand!
4. Remove the front jacket panel.
5. Turn off the gas ball valve. Valve handle should be perpendicular to the gas pipe.
6. Wait 5 minutes for any gas to clear. Then smell for gas, including near the floor. If you smell gas, STOP! Follow instructions on this page under "What To Do If You Smell Gas." If you do not smell gas, go to next step.
7. Turn gas ball valve to the "on" position. The handle on the valve should be parallel to the gas pipe.
8. Replace the front jacket panel.
9. Turn on all electrical power to the appliance.
10. Set thermostat to desired setting.
11. If the appliance will not operate, follow the instructions "To Turn Off Gas To Appliance" (below) and call your service technician or gas supplier.

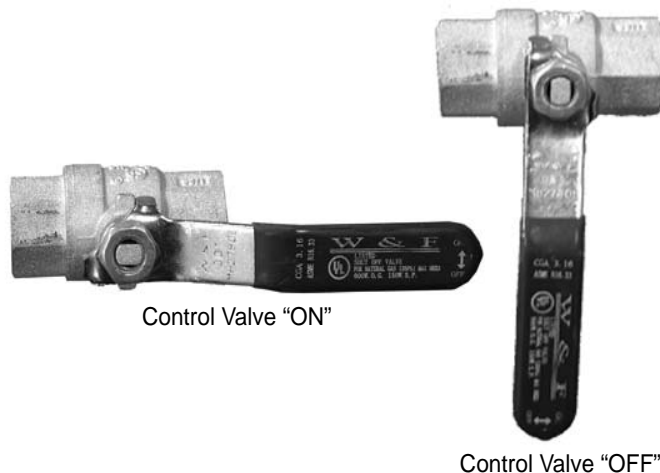

Control Valve "ON"

Control Valve "OFF"

TO TURN OFF GAS TO APPLIANCE

1. Set the thermostat to the lowest setting.
2. Turn off all electric power to the appliance if service is to be performed.
3. Remove the front jacket panel.
4. Turn gas ball valve off, handle should be perpendicular to the gas pipe.
5. Replace the front jacket panel.
6. Safe lighting and other performance criteria were met with the gas manifold and control assembly provided on the boiler when the boiler underwent tests specified in ANSI Z21.13-latest revision.

XIV- MAINTENANCE AND CLEANING

The acidic nature of flue gases condensing on the aluminum boiler sections will cause the formation of aluminum oxide. This oxide formation is normal, is generally uniform throughout the boiler sections, and represents a negligible mass of aluminum that is consumed by oxidation during the life of the boiler. If left unchecked, this buildup may eventually cause blockage of the flue gas passages in the boiler sections, reducing efficiency, and ultimately shutting down the boiler due to lack of combustion air flow, or drainage of condensate.

Regular service and maintenance by a qualified service agency must be performed at least once every 12 months to assure safe, trouble free operation and maximum efficiency.

Beginning of each heating season

1. Schedule an annual service call by a qualified service agency which includes:
 - Examining flue passages in the heat exchanger, burner, and condensate lines, and cleaning (if necessary) by following the instructions in "Annual Examination and Cleaning of Boiler Components" in this section.

- Visually inspecting the venting and air intake system for proper operation, immediately repairing or replacing any sign of deterioration or leakage, and insuring proper reassembly and resealing of the system.
- Checking for and removing any obstruction to the flow of combustion air or venting of flue gases.
- Following the instructions in Sections V and VII of the Control Manual and Operating Instructions (P/N# 240006104), "Putting The Boiler In Operation" and "Checkout Procedures And Adjustments."
- Visually inspecting the condensate drain line for proper operation and checking for deteriorated or plugged condensate drain line.
- Checking all gasketed joints for leakage and tightening bolts or replacing gaskets as needed.
- Removing jacket front and top panels, checking for piping leaks around relief valve and other fittings, and repairing if found WITHOUT USING stop leak compounds.
- Analyze the boiler fluid as instructed in Water Treatment

and Freeze Protection section of manual 240006104.

2. Check that boiler area is free from combustible materials, gasoline, and other flammable vapors and liquids.
3. Circulator pump and blower fan motor furnished with boiler are permanently lubricated from the factory and require no further lubrication. Additional or non-factory supplied pumps and/or motors should be lubricated according to the pump and/or motor manufacturer's instruction.

Daily during heating season

4. Check for and remove any obstruction to the flow of combustion air or venting of flue gases.
5. Check that boiler area is free from combustible materials, gasoline, and other flammable vapors and liquids.

Monthly during heating season

1. Remove jacket front and top panels and check for piping leaks around relief valve and other fittings. If found, contact a qualified service agency. DO NOT use stop leak compounds.
2. Test relief valve. Refer to valve manufacturers instructions packaged with relief valve.
3. Visually inspect the venting and air intake system for proper operation. If the vent or air intake show any signs of deterioration or leakage, contact a qualified service agency to repair or replace them immediately and to insure proper reassembly and resealing of the system.
4. Visually inspect the PVC condensate drain pipe for proper operation. If the drain pipe shows any signs of blockage, leakage, or deterioration contact a qualified service agency to clean, repair, or replace it immediately.
5. Check air vent(s) for leakage.
6. A periodic inspection of the low water cut off is necessary, including flushing of float type devices. Refer to low water cut off manufacturer's specific instructions.

Annual shut down procedure

1. Turn off gas to boiler as described "To Turn Off Gas To Appliance" in Section V of the Control Manual and Operating Instructions (P/N# 240006104).
2. If heating system is to remain out of service during freezing weather and does not contain antifreeze, drain system completely. If boiler will be exposed to freezing temperatures, drain condensate lines.

Annual examination and cleaning of boiler components



WARNING

The following service procedures must be performed by a qualified service agency using the Repair Parts Manual (P/N# 240006107) for reference. The boiler owner should not attempt these steps.

1. Before servicing, turn off electrical power to boiler at service switch. Close manual gas valve to turn off gas supply to boiler.
2. Examine flue passages by removing blower/burner assembly from casting. The procedure for examining and cleaning the burner is described below.
3. Any buildup of sediment or aluminum oxide (white powdery or flaky substance) in the flue passages must be cleaned as follows:

- Remove jacket front and top panels.
- Confirm that manual gas valve is closed and disconnect gas line to gas valve at union. Then disconnect pressure switch hoses to gas valve and air inlet.
- Disconnect wires to gas valve and igniter.
- Loosen but do not remove five nuts attaching blower adapter assembly to boiler.
- Remove two igniter screws and very carefully remove the igniter.
- Remove five nuts and remove blower adapter assembly, burner, and gaskets.
- Aluminum oxide deposits are water soluble and may be rinsed away by inserting a hose into the burner opening of the casting and slowly running water through the flue side of the boiler and out the condensate drain.



CAUTION

Debris rinsed away by this method will exit through the condensate drain. Be wary of drain lines getting clogged and causing water to back up in the bottom of the casting.

- Use a flexible handle nylon brush to loosen sediment and aluminum oxide on all accessible heating surfaces of the boiler. Be sure not to get brush stuck in heat exchanger!
- After brushing and rinsing, remove any remaining loos-

ened sediment using a shop vacuum with a snorkel attachment.

- Inspect burner for any foreign matter in the flame ports or inside the burner. Any foreign matter should be removed by blowing with compressed air or vacuuming. If the burner cannot be cleaned, it must be replaced.
- Reinstall burner and gaskets and position blower adapter assembly over studs. Install five nuts but do not tighten. Reinstall igniter and igniter gasket and fasten with two screws. Tighten five nuts holding blower adapter assembly.
- Connect gas line to gas valve, pressure switch hose to gas valve and air inlet assembly, igniter wires, and gas valve wires.

4. Visually inspect the condensate trap. Any foreign material visible in the condensate lines needs to be cleaned out as described below:

- Inspect for sediment or blockage.
- Flush out with water or vacuum.
- Follow the instructions in Section VII, “Filling The Condensate Trap With Water.”

5. Inspect the flue connector as follows:

- Loosen the clamp on the vent tee side of the 2” flexible coupling that connects the vent tee to the exhaust port.
- Inspect interior of vent tee. Any buildup of sediment on the inside surface must be cleaned.
- Reconnect 2” flexible coupling to vent tee.

XV - BOILER WIRING DIAGRAM

ELECTRICAL WIRING DIAGRAM (DIAGRAMME DE CÂBLAGE ÉLECTRIQUE)

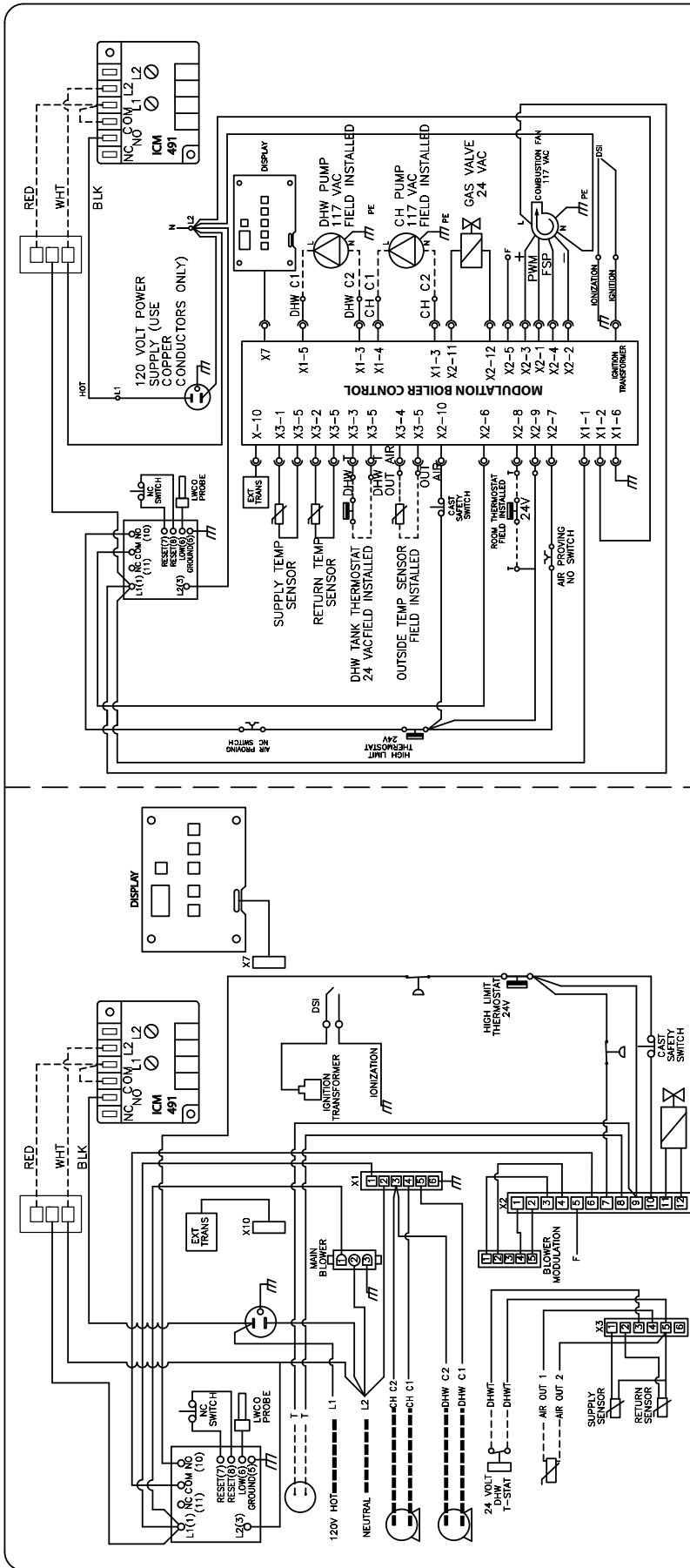

COMPONENT CODING (CODE DES COMPOSANTES)

WIRING (CÂBLAGE)	
—	LINE VOLTAGE BY FACTORY / LIGNE DE VOLTAGE PAR L'USINE
---	LOW VOLTAGE BY FACTORY / BAS VOLTAGE PAR L'USINE
---	LINE VOLTAGE BY INSTALLER / LIGNE DE VOLTAGE PAR L'INSTALLATEUR
---	LOW VOLTAGE BY INSTALLER / BAS VOLTAGE PAR L'INSTALLATEUR

MS	MANUAL SWITCH / INTERRUPTEUR MANUEL
CR	CIRCULATOR / CIRCUULATEUR
LWCO	LOW WATER CUT-OFF
EMF	ELECTRIC WATER FEEDER / ALIMENTEUR ÉLECTRIQUE D'EAU
PG	POWER GENERATOR / GÉNÉRATEUR
PSC	PILOT SAFETY COIL / BOBINE DE SÛRETÉ DE LA VELLEUSE
—	WIRE CONNECTION / RACCORD DES FILS

MR-PS	MANUAL RESET PRESSURE SW. / REMISE EN MARCHÉ MANUEL DE L'INTERRUPTEUR DE PRESSION
SD	STACK DAMPER / REGISTRE DE LA CHEMINÉE
—	RELAY CONTACTS / CONTACTS DU RELAIS
1 K1	RELAY CONTACTS / CONTACTS DU RELAIS
1 K2	RELAY CONTACTS / CONTACTS DU RELAIS
1 LS	LIMIT SWITCH / INTERRUPTEUR DE LIMITE
F	FLAME SENSING / FLAMME SENSING

NOTE: 1. SWITCHES ARE SHOWN IN POSITION TAKEN DURING HEATING CYCLE. / (LES INTERRUPTEURS SONT MONTRES EN POSITION DE CYCLE DE CHAUFFANT.)
 2. IF ANY OF THE ORIGINAL WIRING SUPPLIED WITH THE BOILER IS REPLACED, IT MUST BE REPLACED WITH LIKE WIRE SIZE AND TYPE OF INSULATION OR EQUIVALENT. / (SI AUCUN DES FILS ORIGINAUX FOURNIS AVEC LA CHAUDIÈRE EST REMPLACÉ, IL DOIT ÊTRE REMPLACÉ PAR UN AUTRE FIL DE MÊME GROSSEUR ET DU MÊME TYPE D'ISOLATION OU L'ÉQUIVALENT.)

* NOT ALL COMPONENTS LISTED ARE USED IN ALL CONTROL SYSTEMS. (LES COMPOSANTES ÉNUMÉRÉES NE SONT PAS TOUTES UTILISÉES DANS TOUS LES SYSTÈMES DE CONTRÔLES.)

2440007204, REV B

Boiler Control Wiring Diagram: Single Zone System With Domestic Hot Water Priority

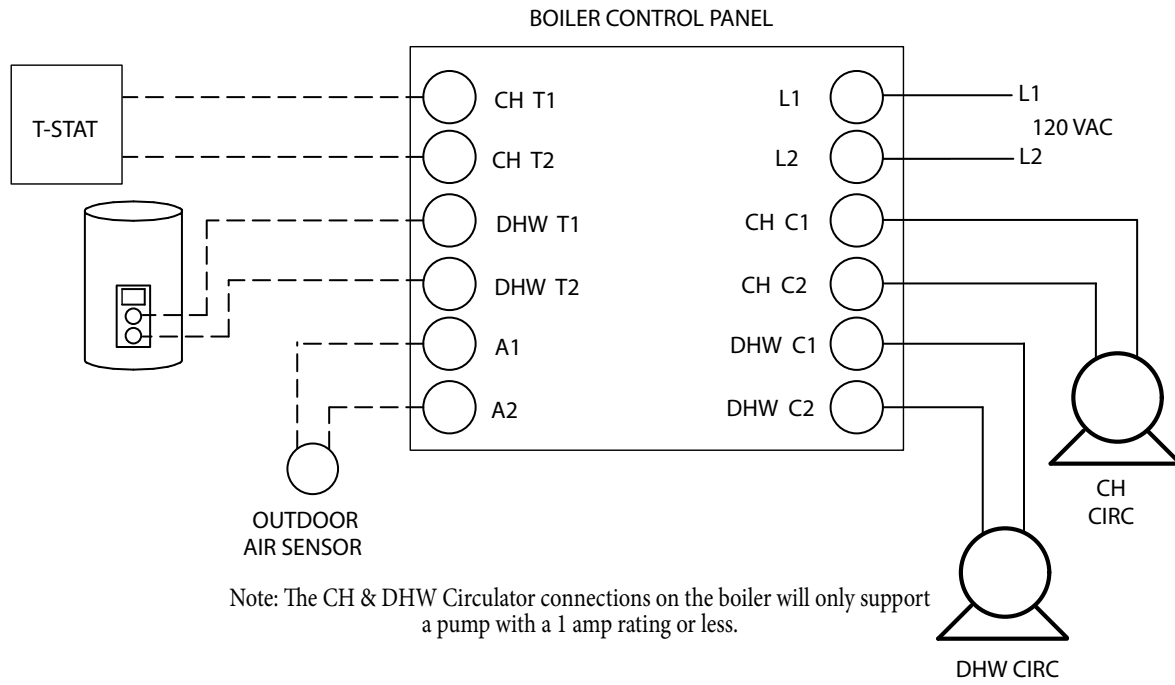

Piping Diagram 1: Single Zone System With Domestic Hot Water Priority

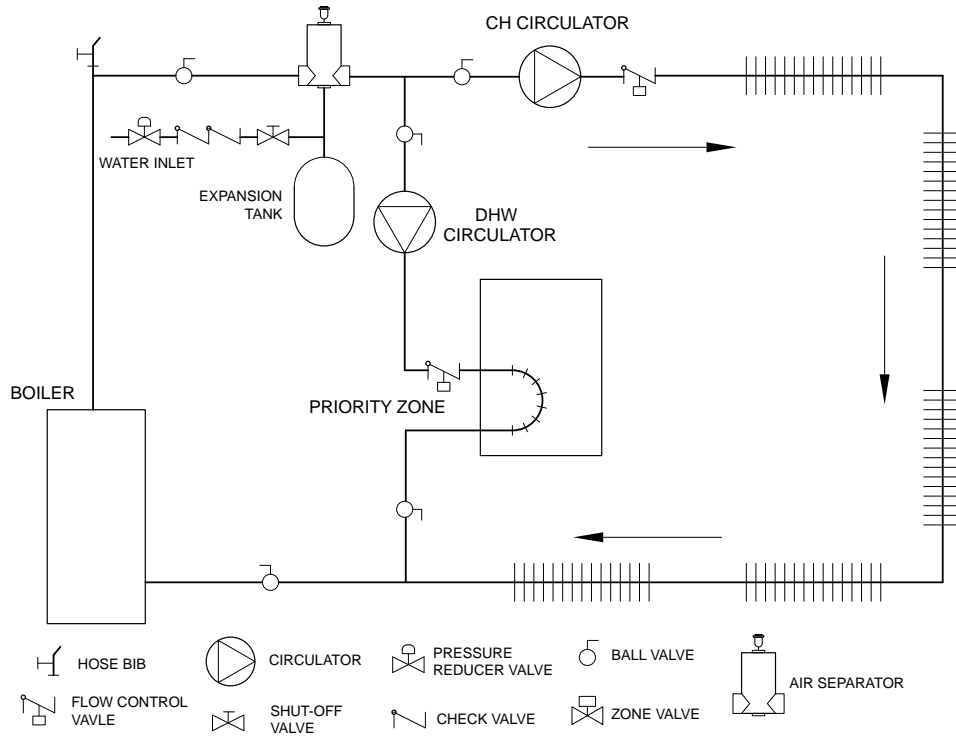

NOTE: NOT RECOMMENDED FOR ANTIFREEZE APPLICATIONS

Wiring Diagram 1 : Single Zone System With Domestic Hot Water Priority

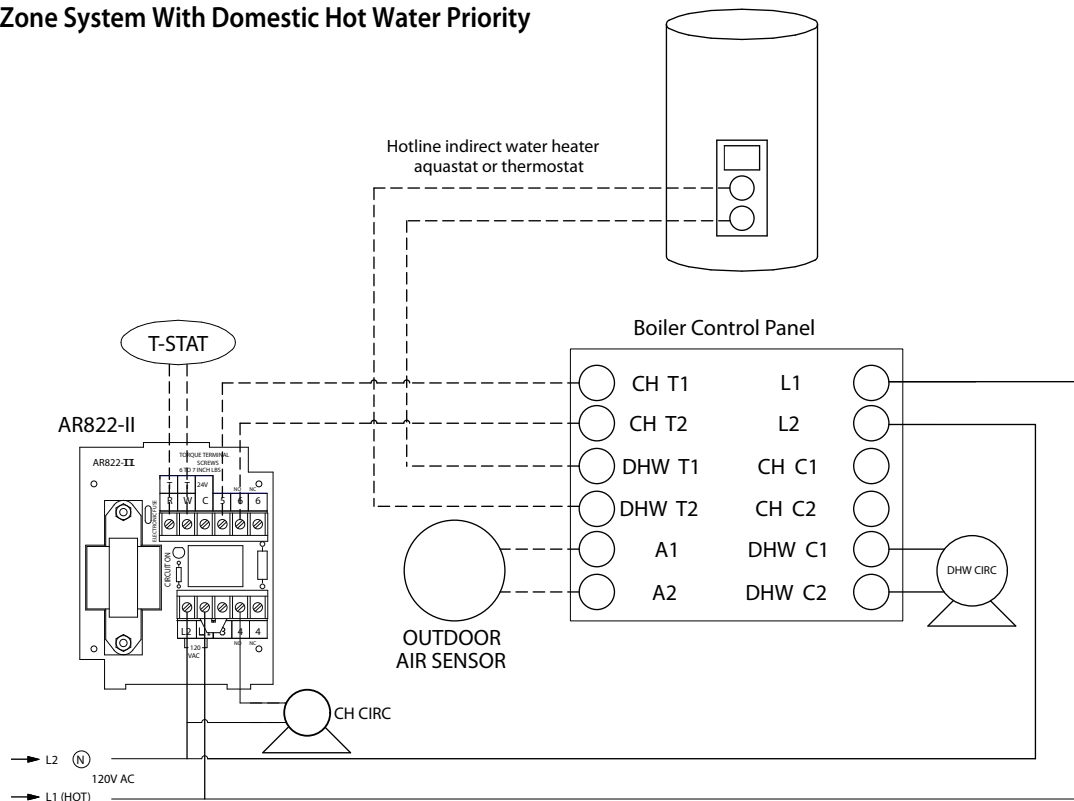

Piping Diagram 2 : Multizone Piping With Zone Valves And Domestic Hot Water Priority (With Zone Valve)

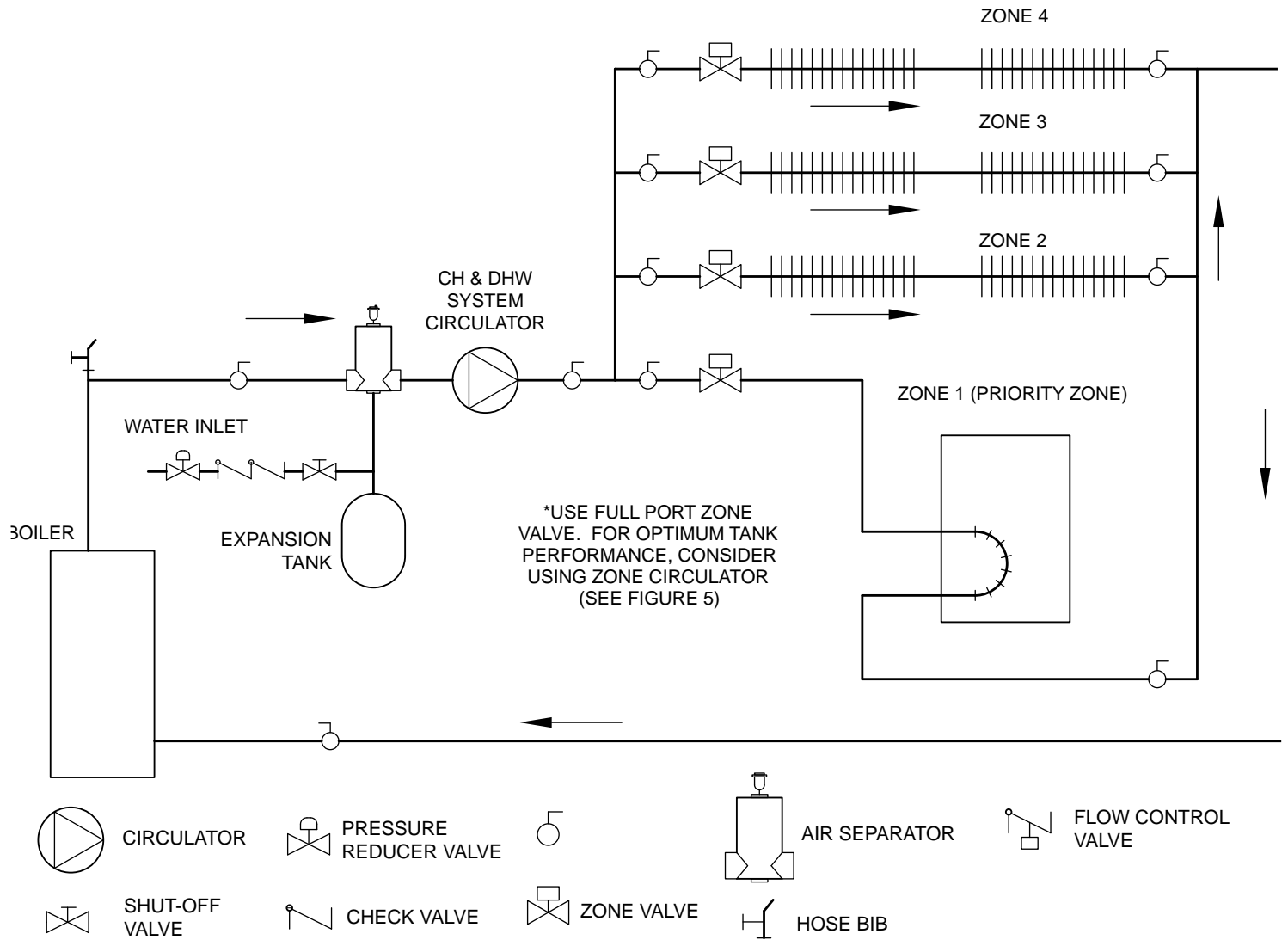

NOTE: NOT RECOMMENDED FOR ANTIFREEZE APPLICATIONS

Wiring Diagram 2: Multizone Wiring With Zone Valves And Domestic Hot Water Priority (With Zone Valve)

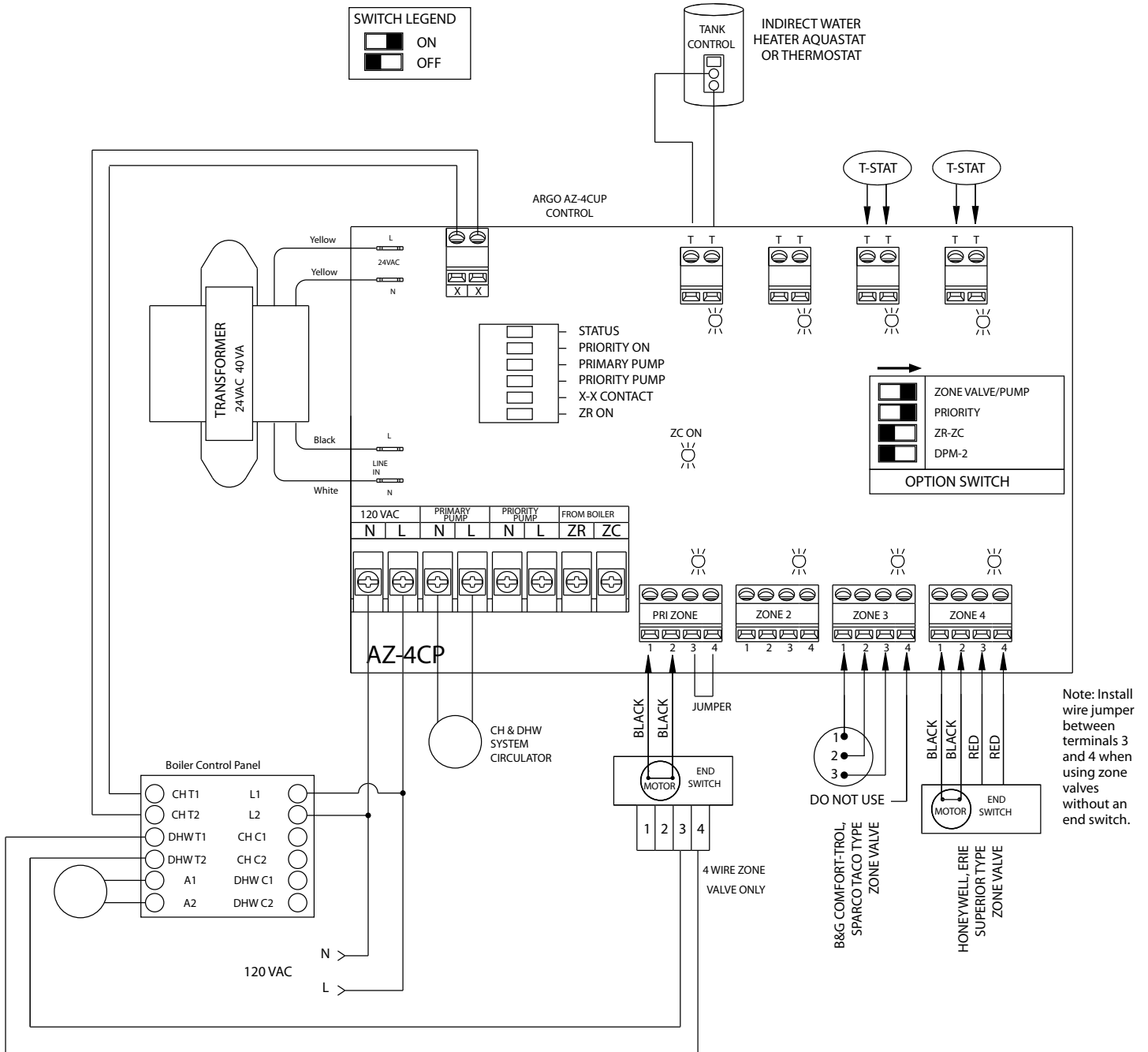

Piping Diagram 3 : Multizone System With Zone Valves And Domestic Hot Water Priority (With Circulator)

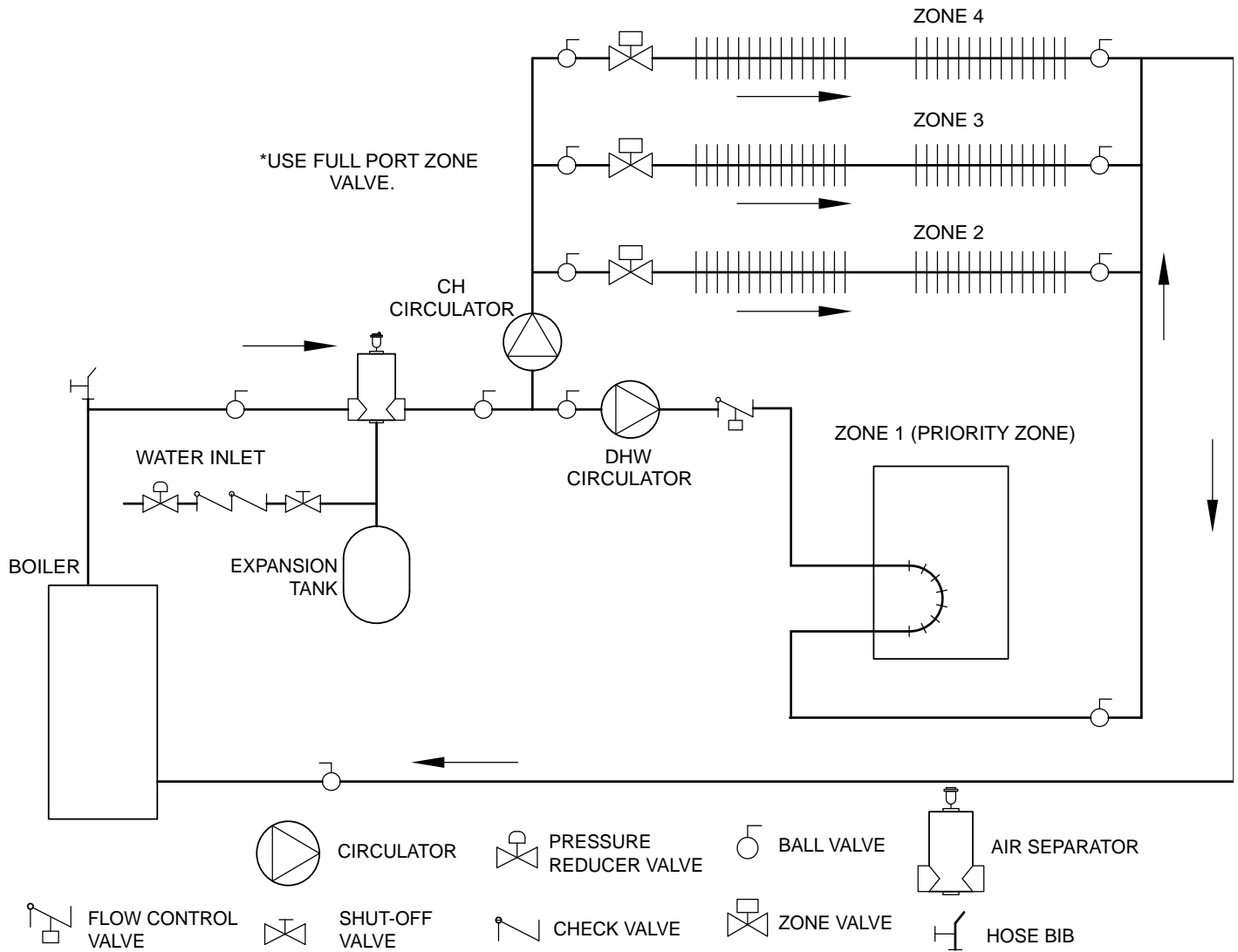

NOTE: NOT RECOMMENDED FOR ANTIFREEZE APPLICATIONS

Wiring Diagram 3: Multizone System With Zone Valves And Domestic Hot Water Priority (With Circulator)

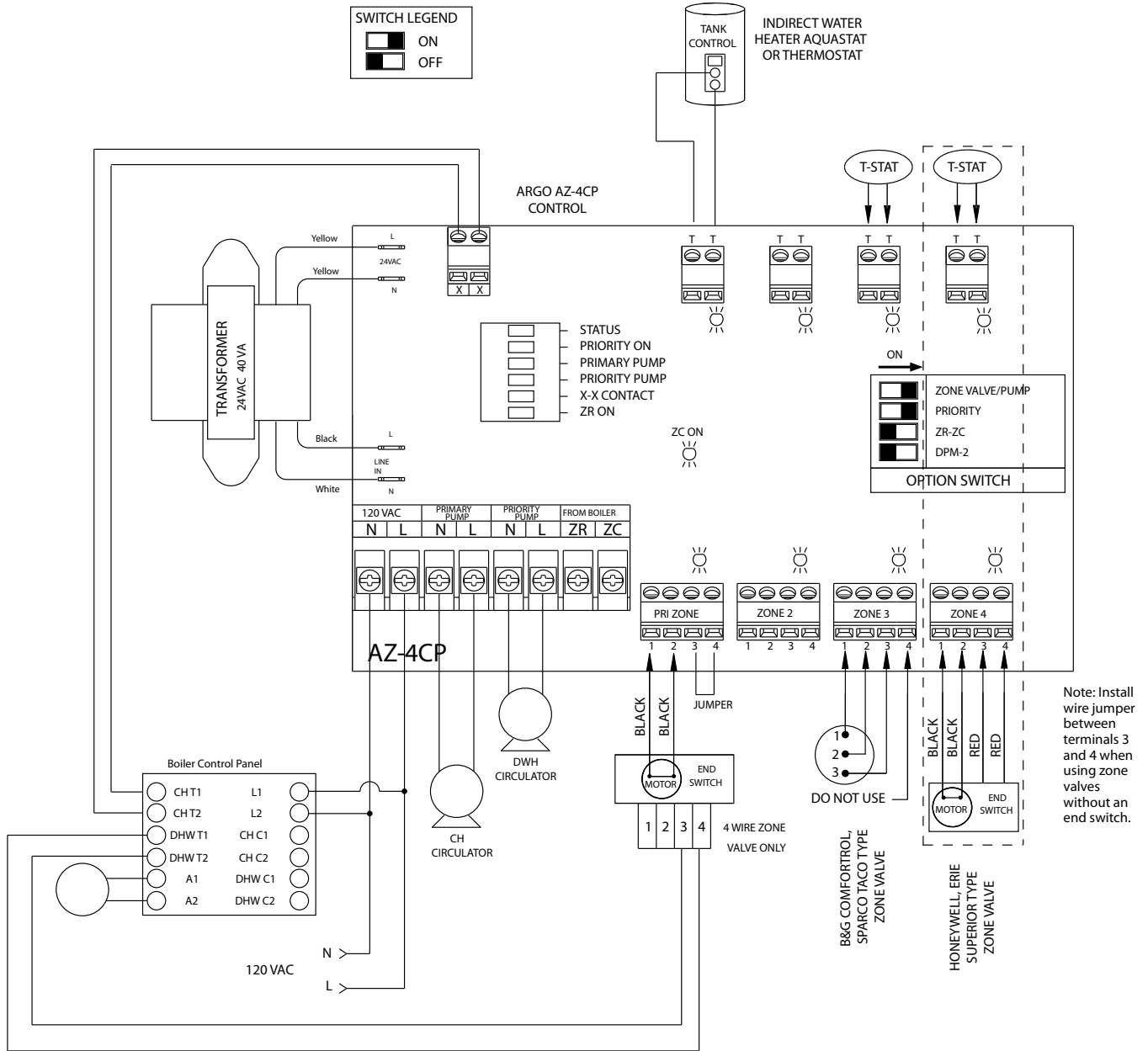

Piping Diagram 4: Multizone System With Circulators And Domestic Hot Water Priority

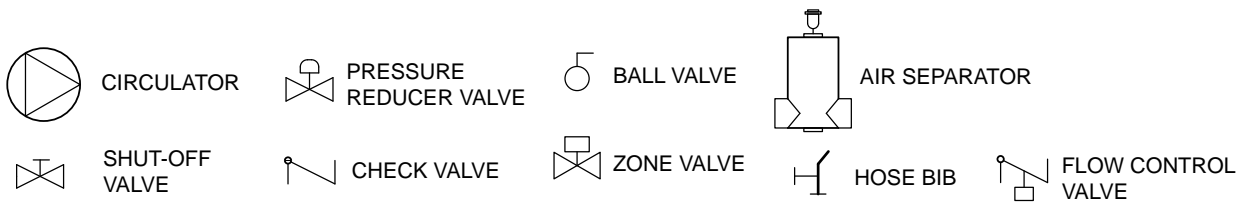
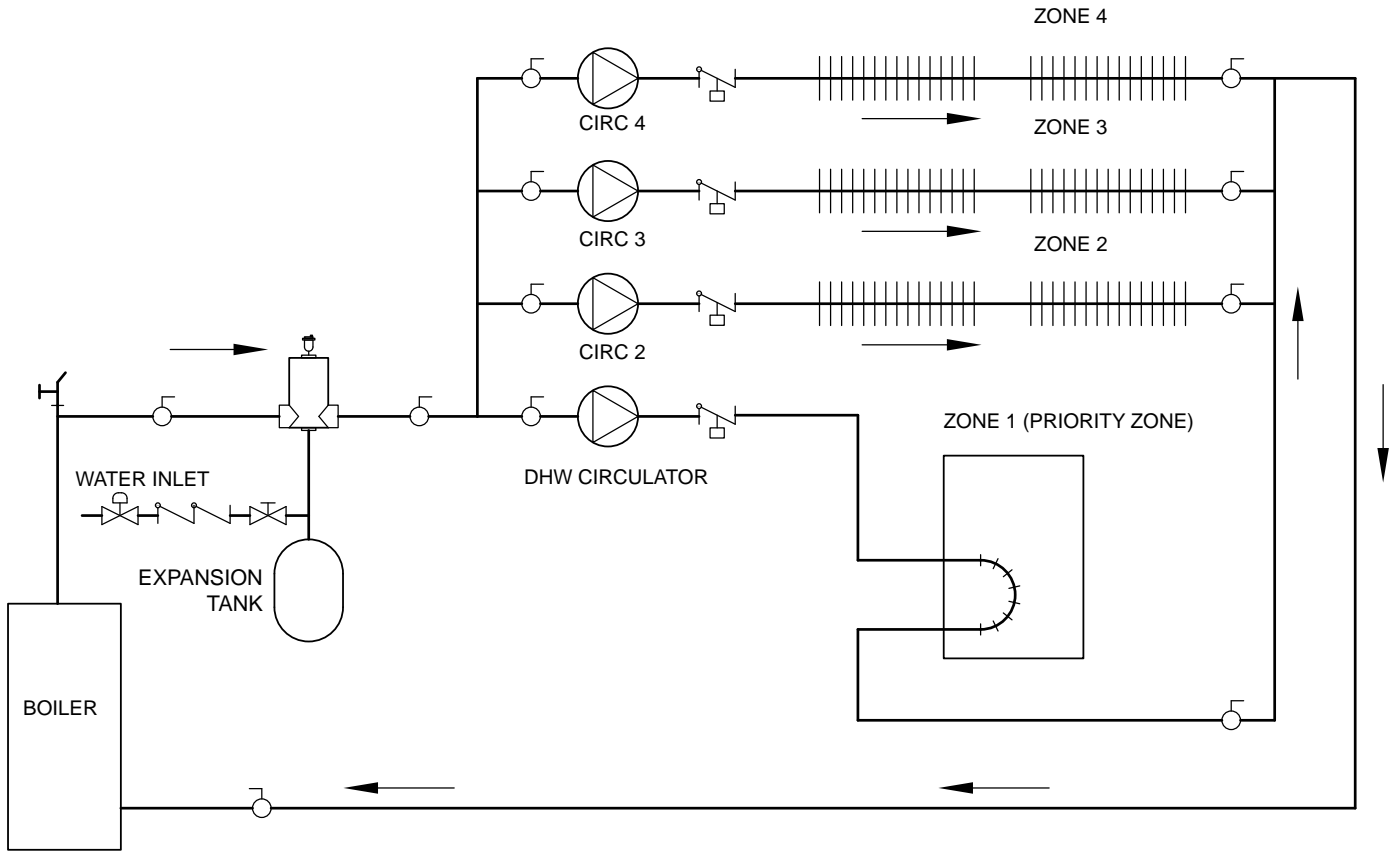

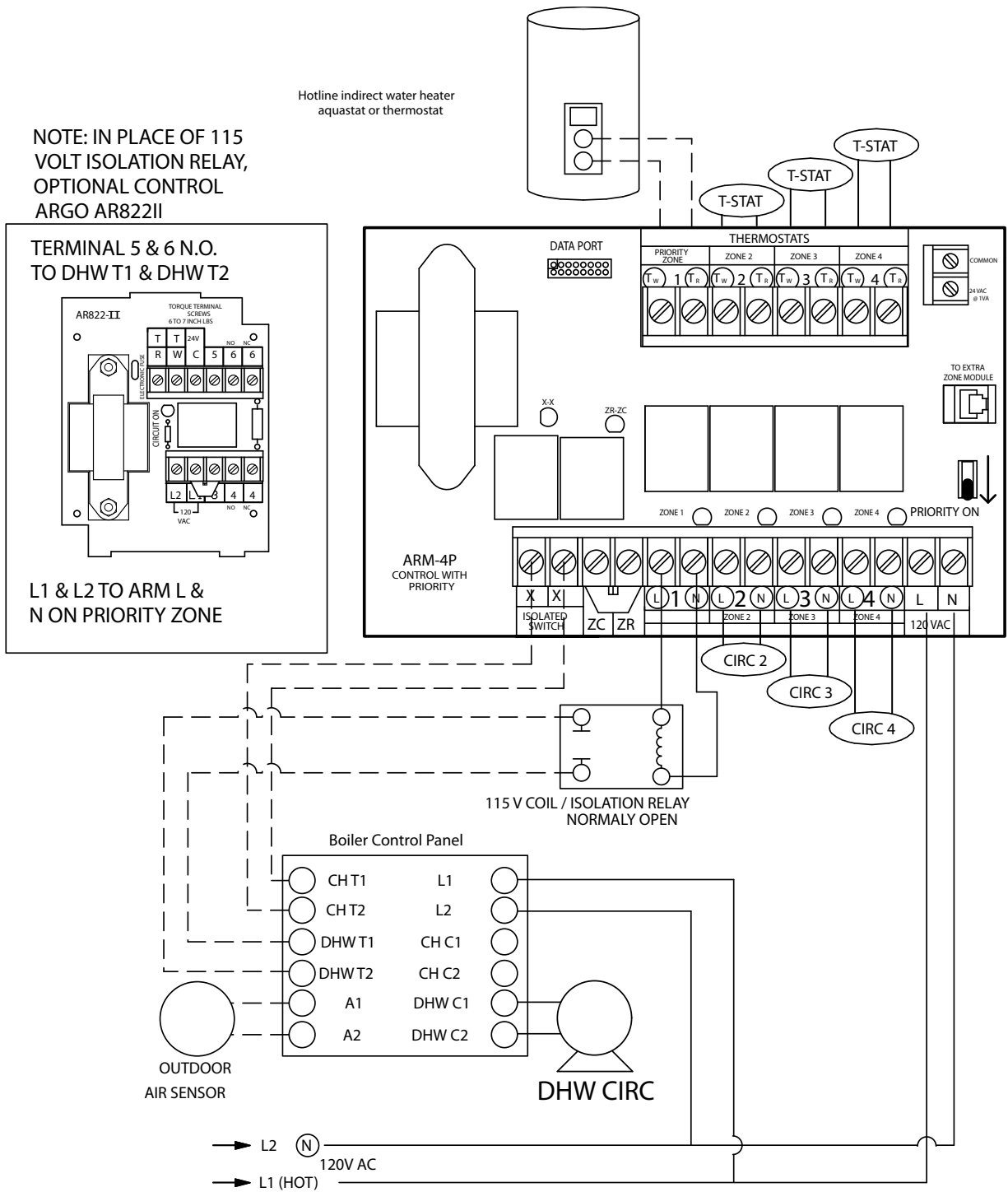

NOTE: NOT RECOMMENDED FOR ANTIFREEZE APPLICATIONS

Wiring Diagram 4: Multizone System With Circulators And Domestic Hot Water Priority

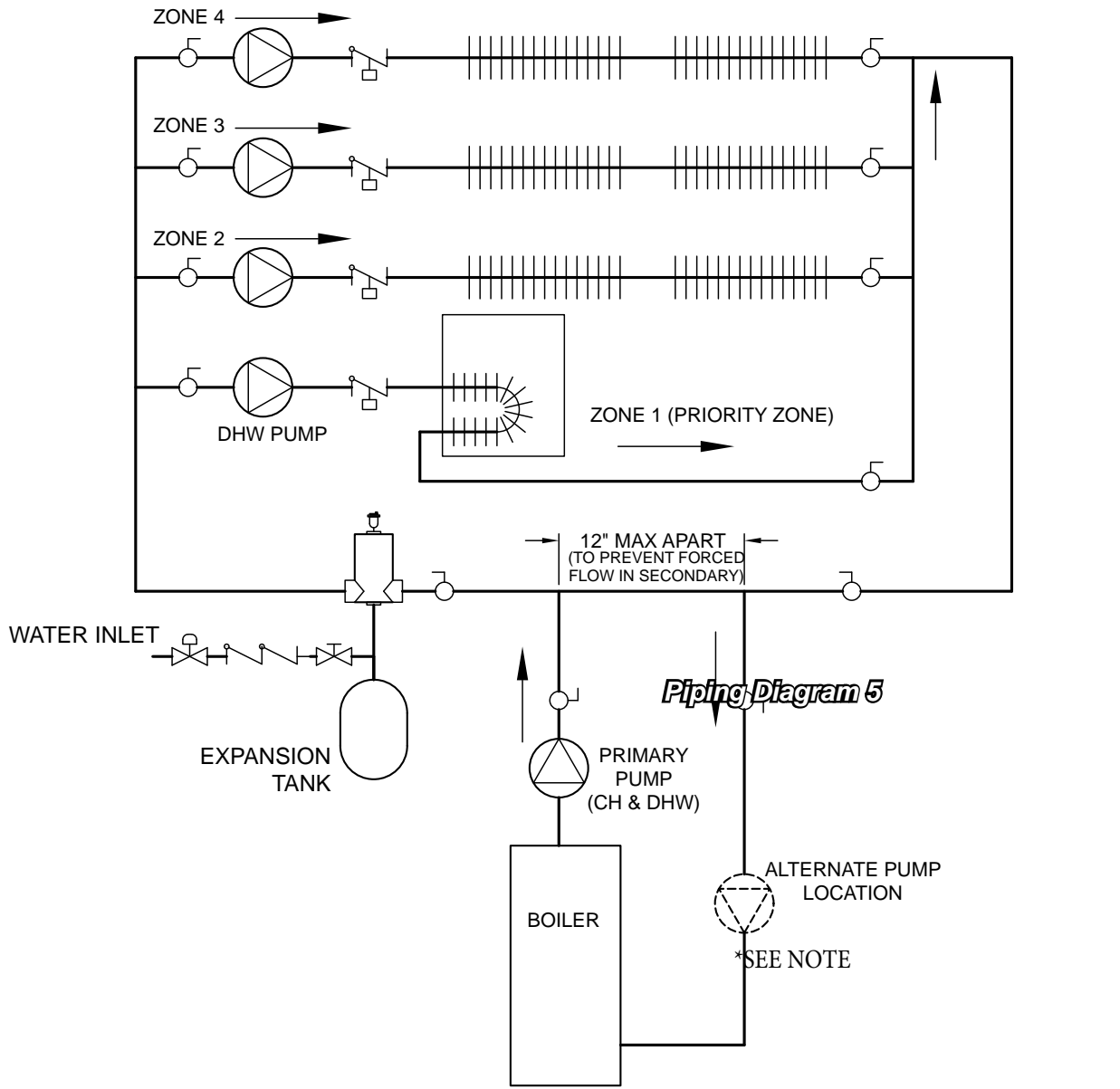

Piping Diagram 5 : Primary/Secondary Piping With Circulators And Domestic Hot Water



 FLOW CONTROL VALVE

 CIRCULATOR (PUMP)

 SHUT-OFF VALVE

 PRESSURE REDUCER VALVE

 CHECK VALVE

 BALL VALVE

 ZONE VALVE

 AIR SEPARATOR

 HOSE BIB

NOTE: RECOMMENDED FOR ANTIFREEZE APPLICATIONS

Wiring Diagram 5 : Primary/Secondary Wiring With Circulators And Domestic Hot Water

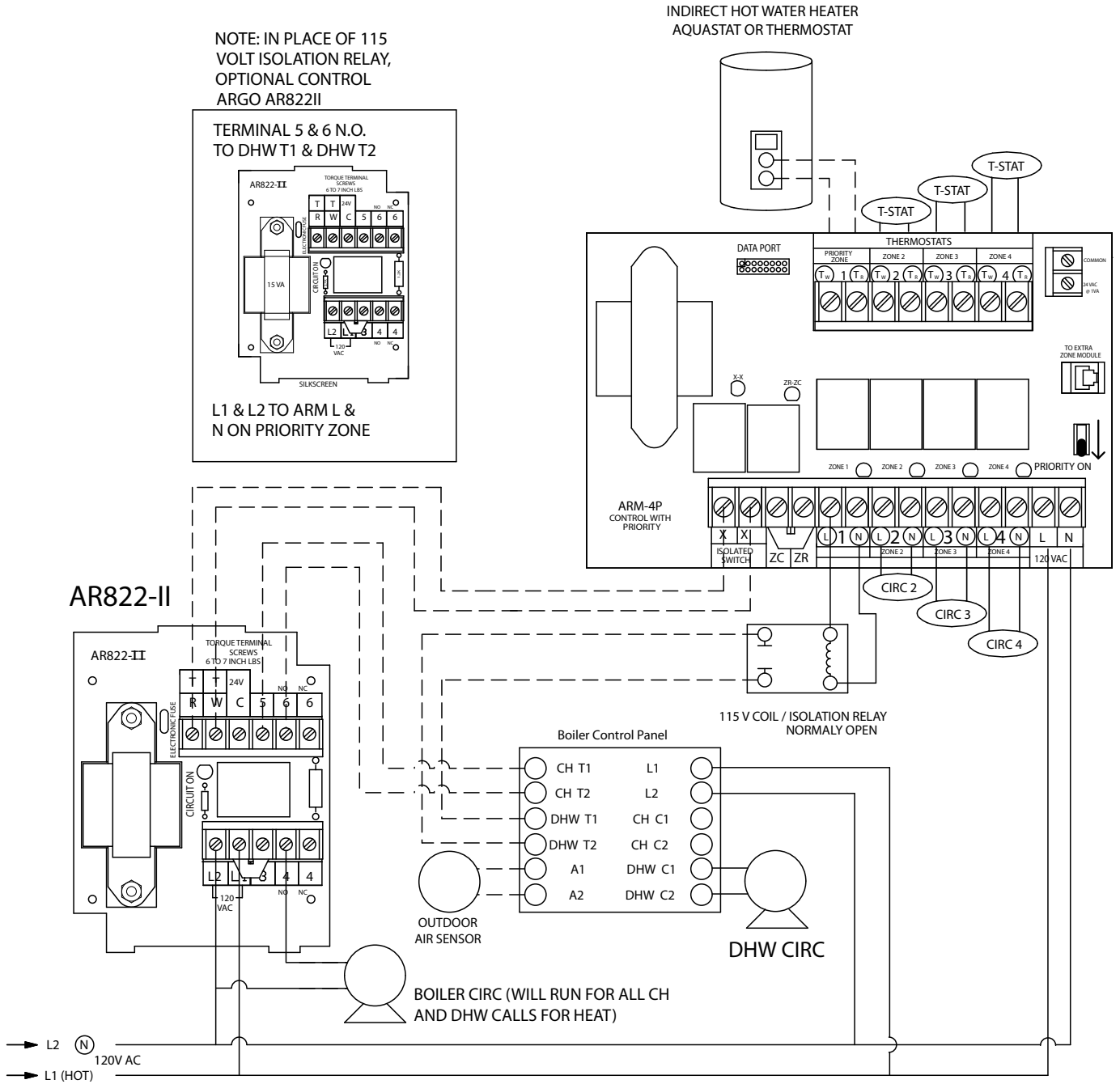

Piping Diagram 6 : Primary/Secondary Multizone System Piping With Zone Valves And Domestic Hot Water (With Zone Valve)

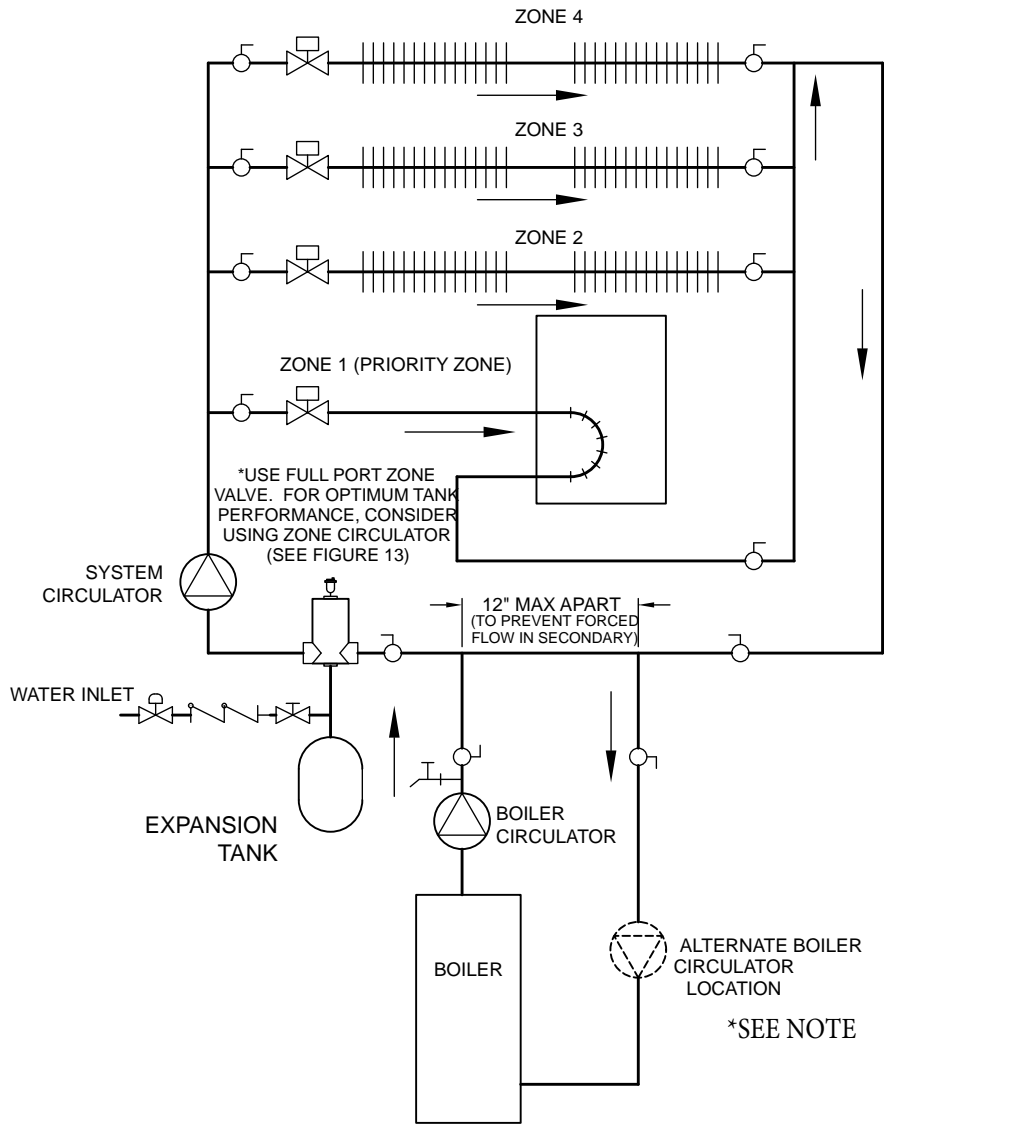

FLOW CONTROL VALVE



CIRCULATOR



PRESSURE REDUCER VALVE



BALL VALVE

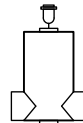

AIR SEPARATOR



SHUT-OFF VALVE



CHECK VALVE



ZONE VALVE



HOSE BIB

NOTE: RECOMMENDED FOR ANTIFREEZE APPLICATIONS

Wiring Diagram 6 : Primary/Secondary Multizone System Wiring With Zone Valves And Domestic Hot Water (With Zone Valve)

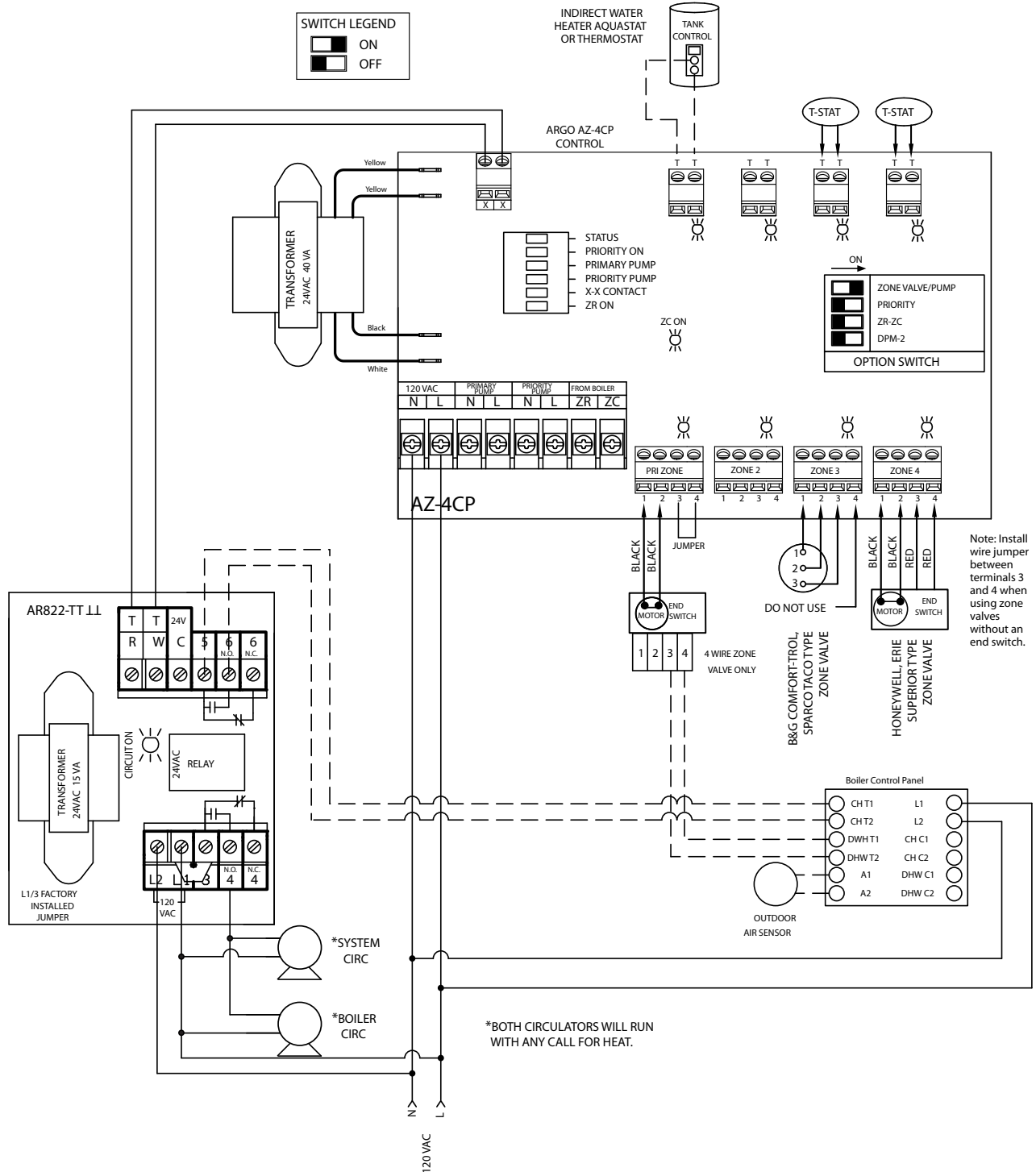

Note: a priority loop zone valve is used with this configuration

Piping Diagram 7 : Primary/Secondary Piping With Zone Valves And Domestic Hot Water (With Circulator)

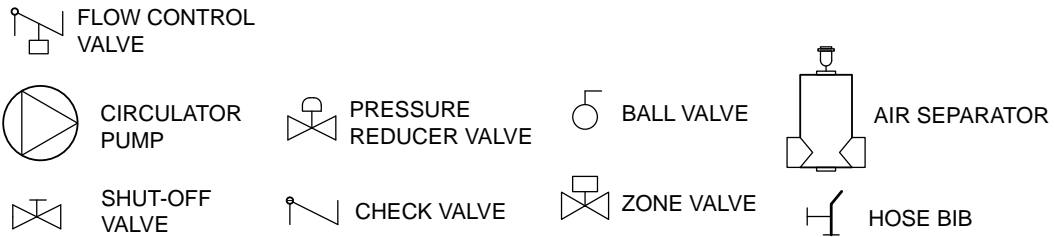
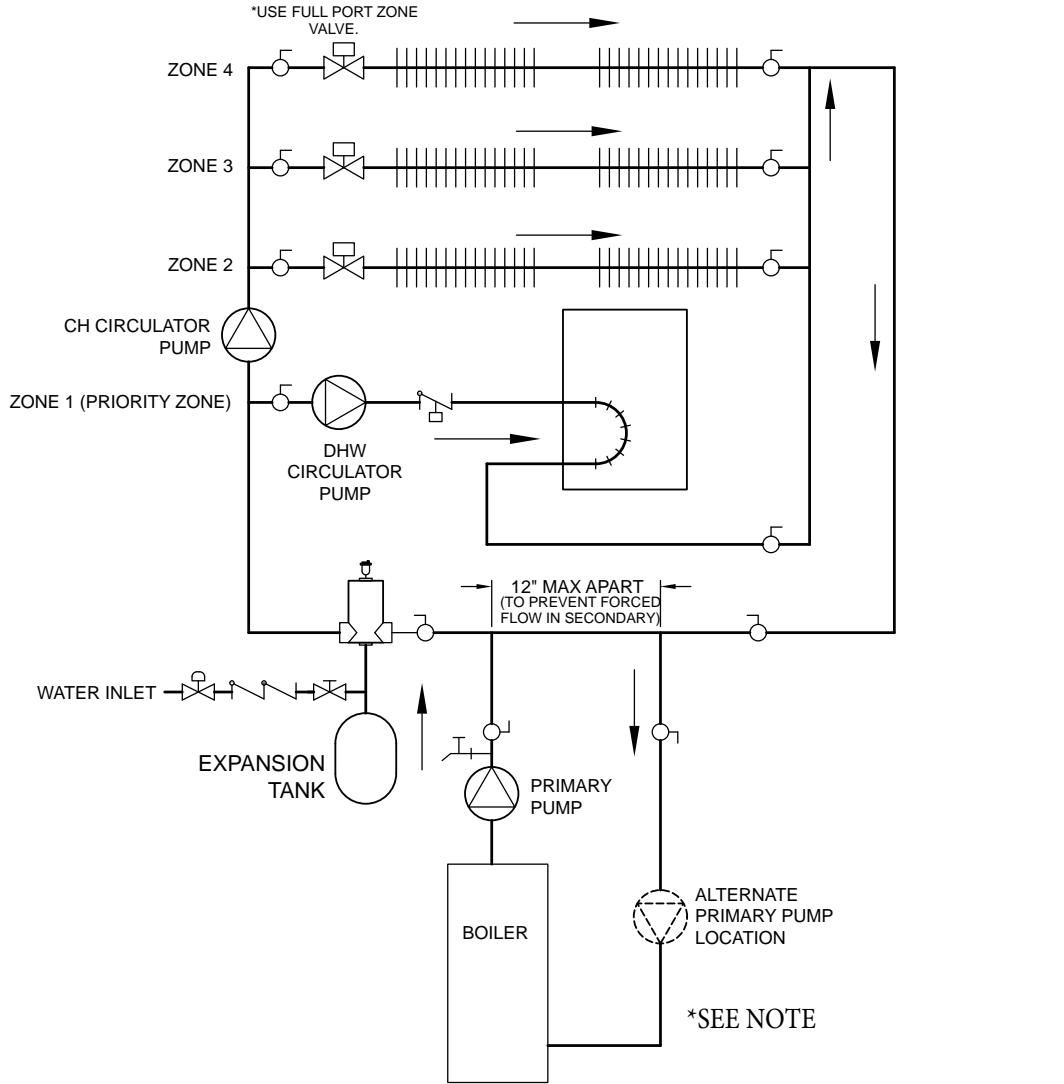

NOTE: RECOMMENDED FOR ANTIFREEZE APPLICATIONS

Wiring Diagram 7 : Primary/Secondary Piping With Zone Valves And Domestic Hot Water (With Circulator)

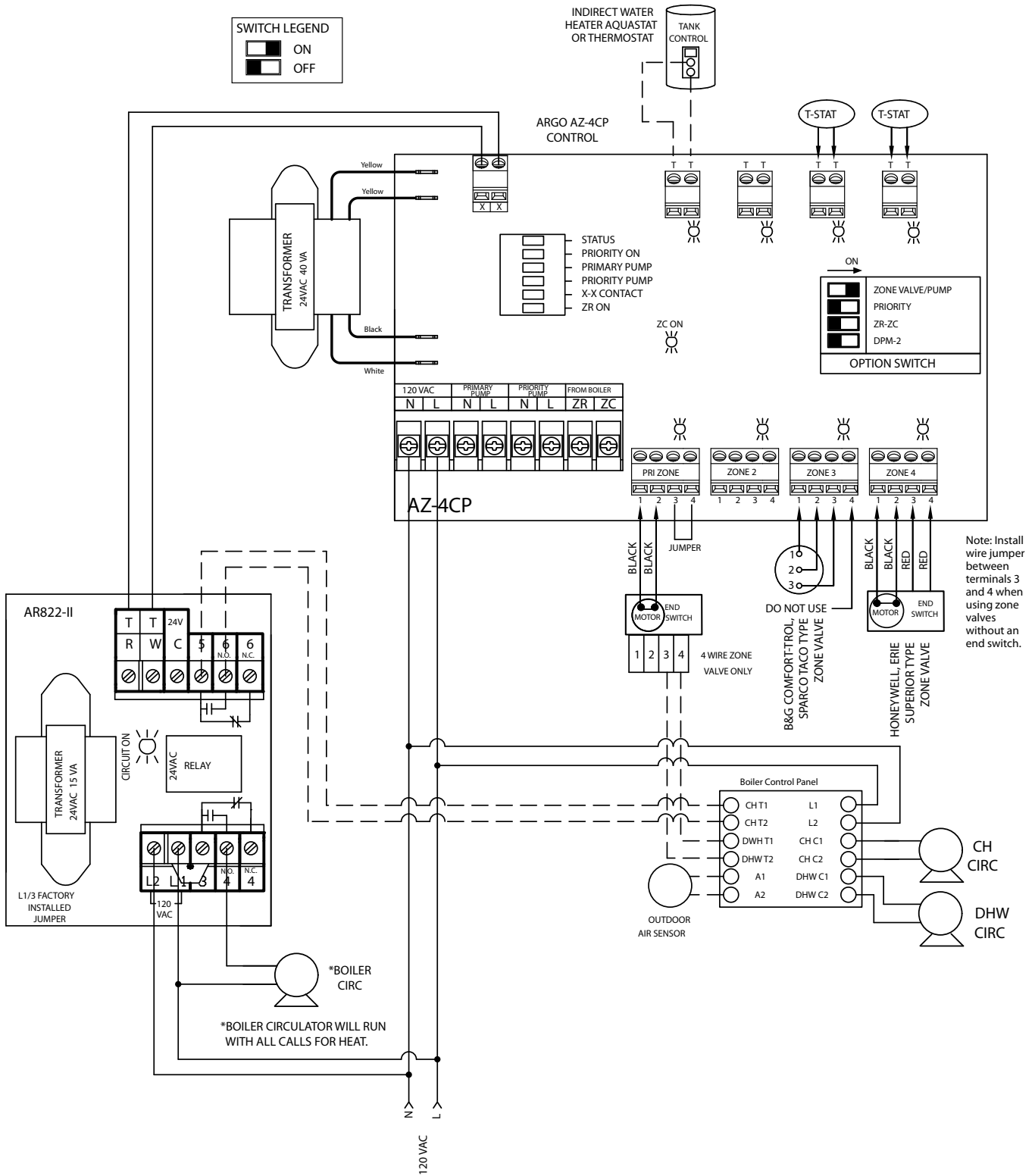

Note: a priority loop zone valve is used with this configuration

Piping Diagram 8 : Bypass Piping (Automatic Mixing Valve)

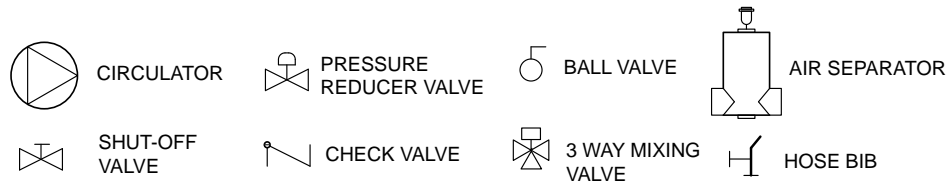
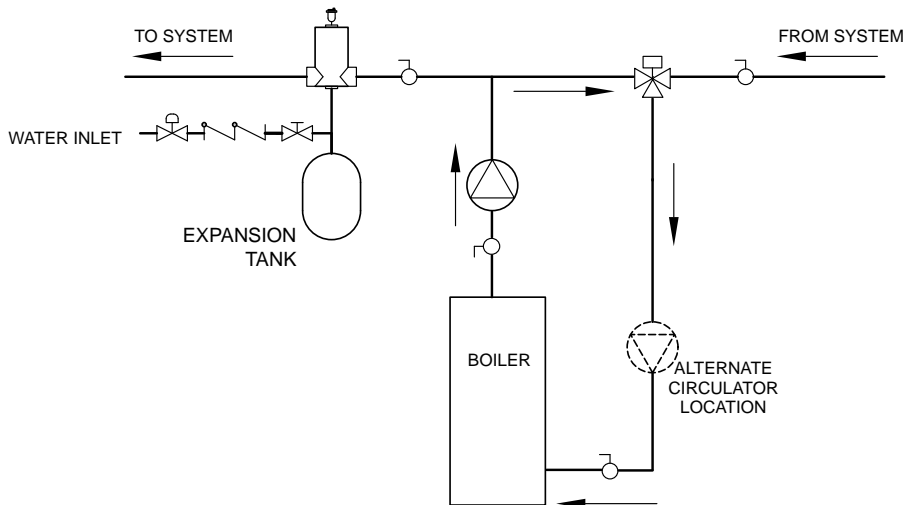

Piping Diagram 9 : Bypass Piping (Fixed Low Temp Only)

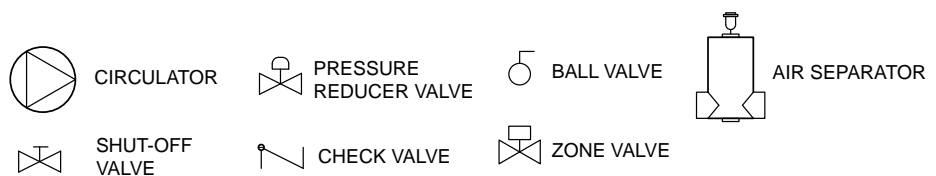
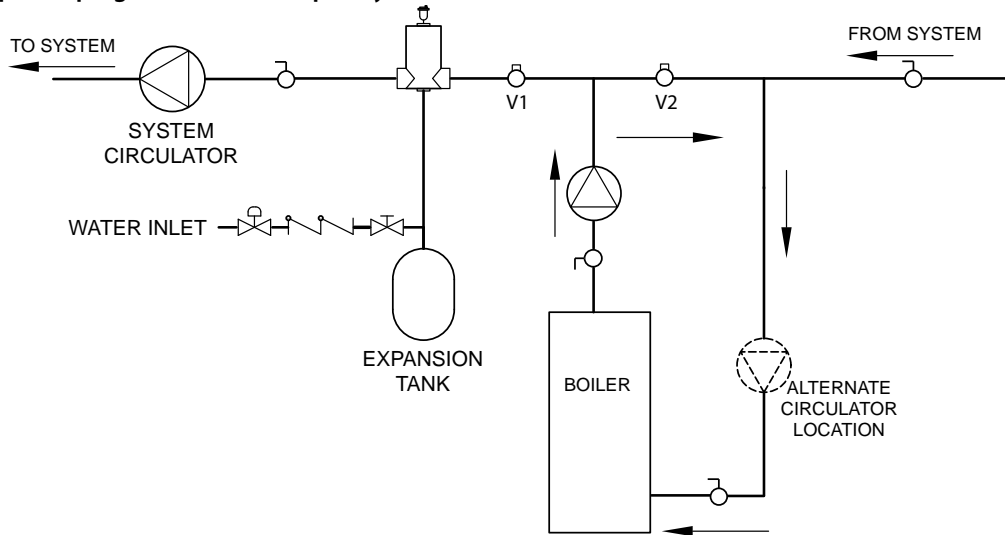

Piping Diagram 10 : Bypass Piping (4-Way Valve Option With Circulator On Supply)

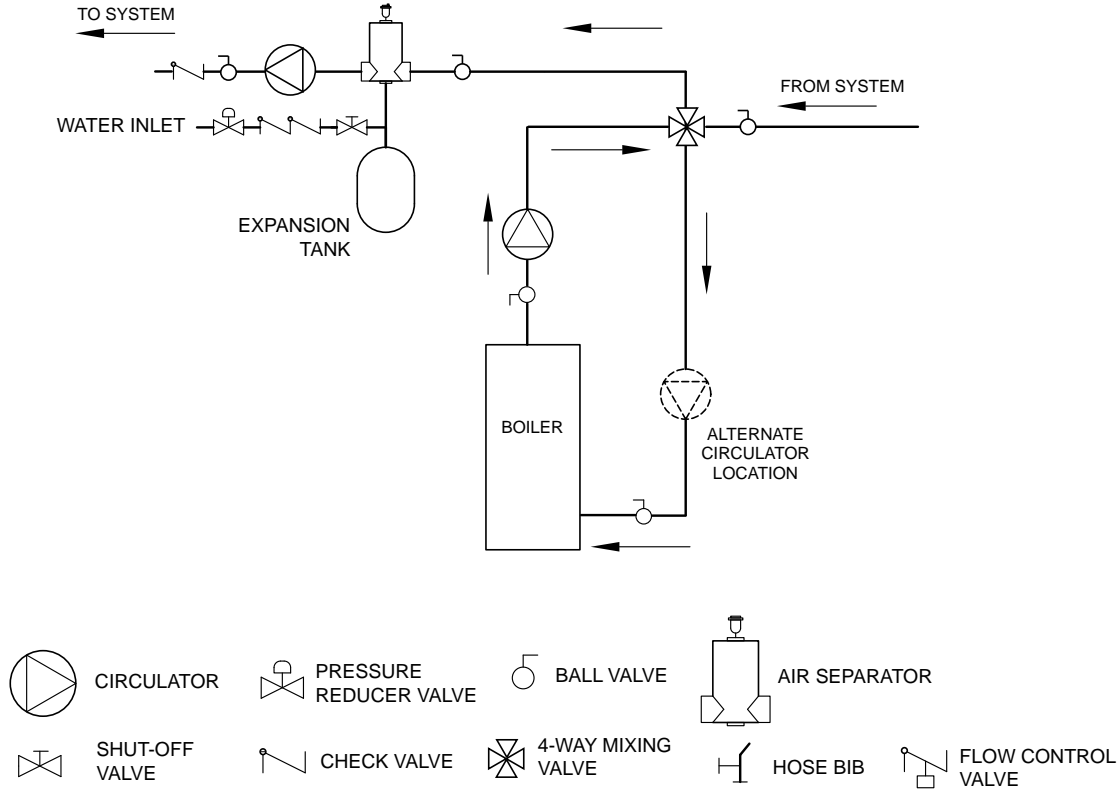

Piping Diagram 11 : Multiple Boiler Piping

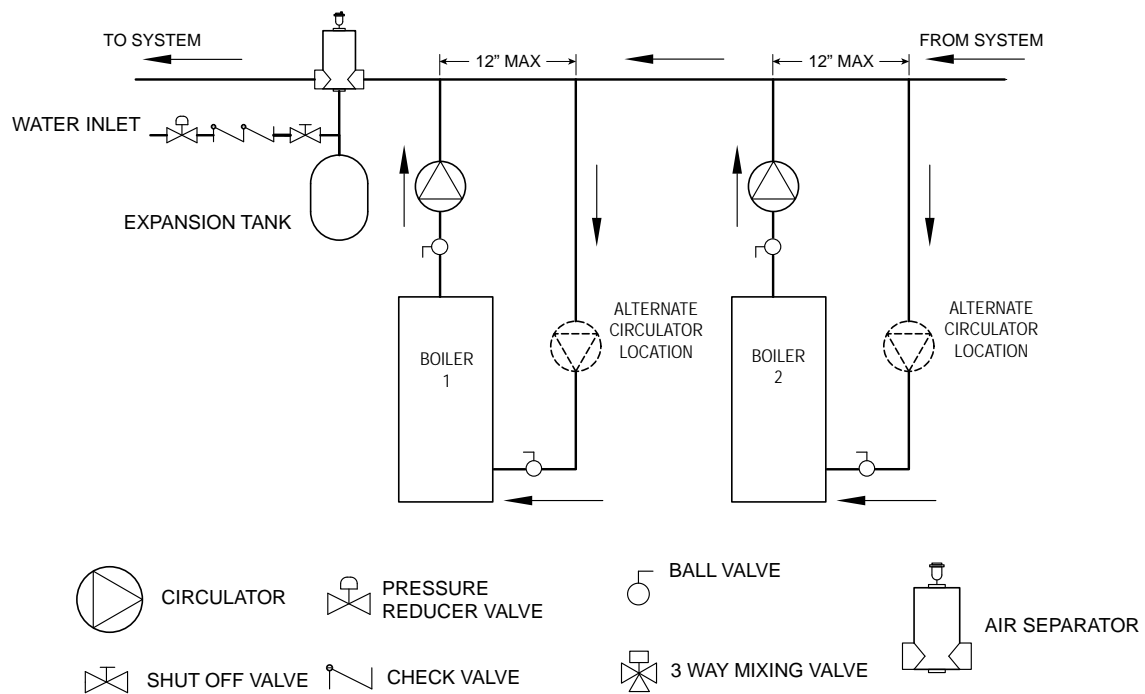

Wiring Diagram 9: Multiple Boiler Wiring (AMB-4)

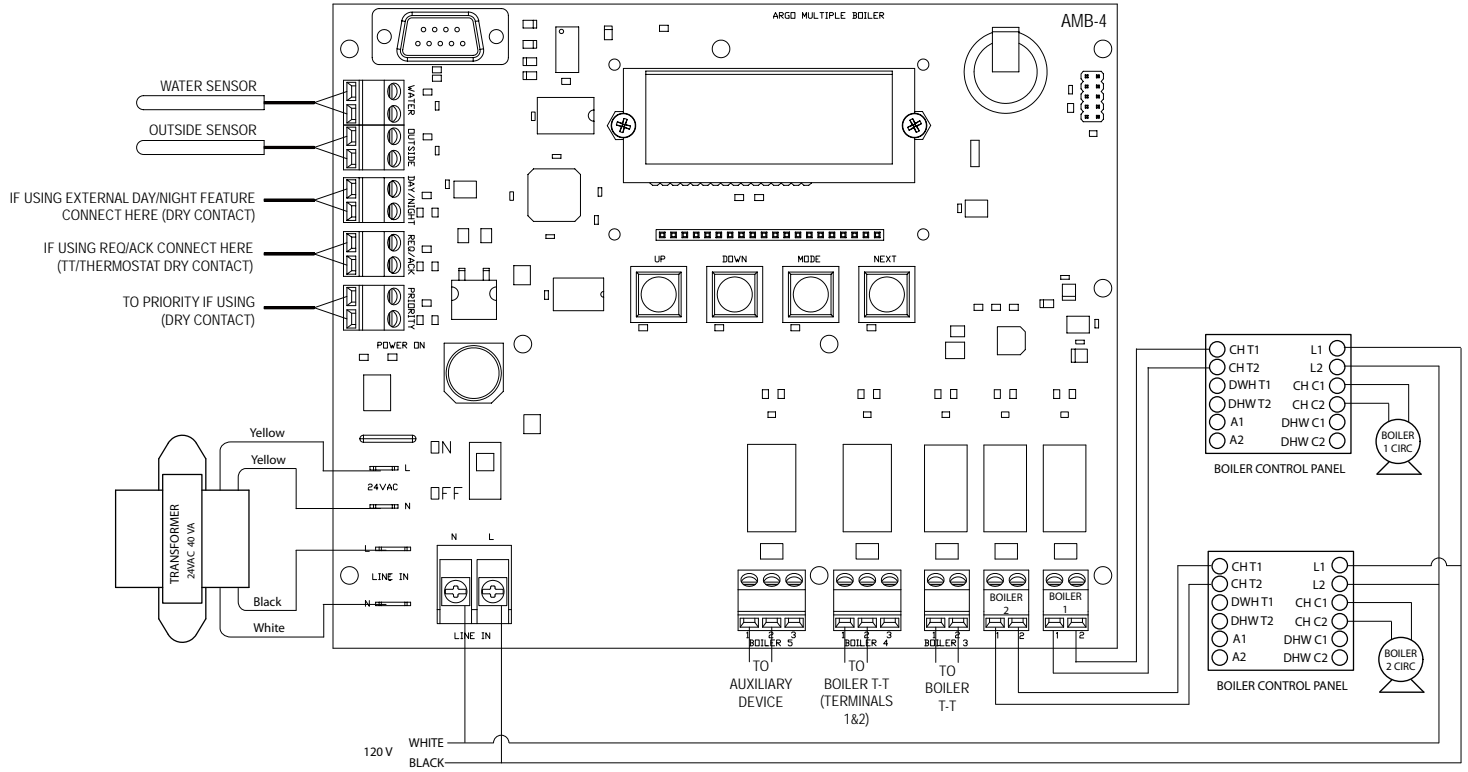

Wiring Diagram 10: Multiple Boiler Wiring (AMB-8)

